



Reliable, convenient, and powerful power solution
Exquisite industrial sensor technology

Sensor

Proximity switch
Photoelectric switch

■ The Integrated Solution of Control Component

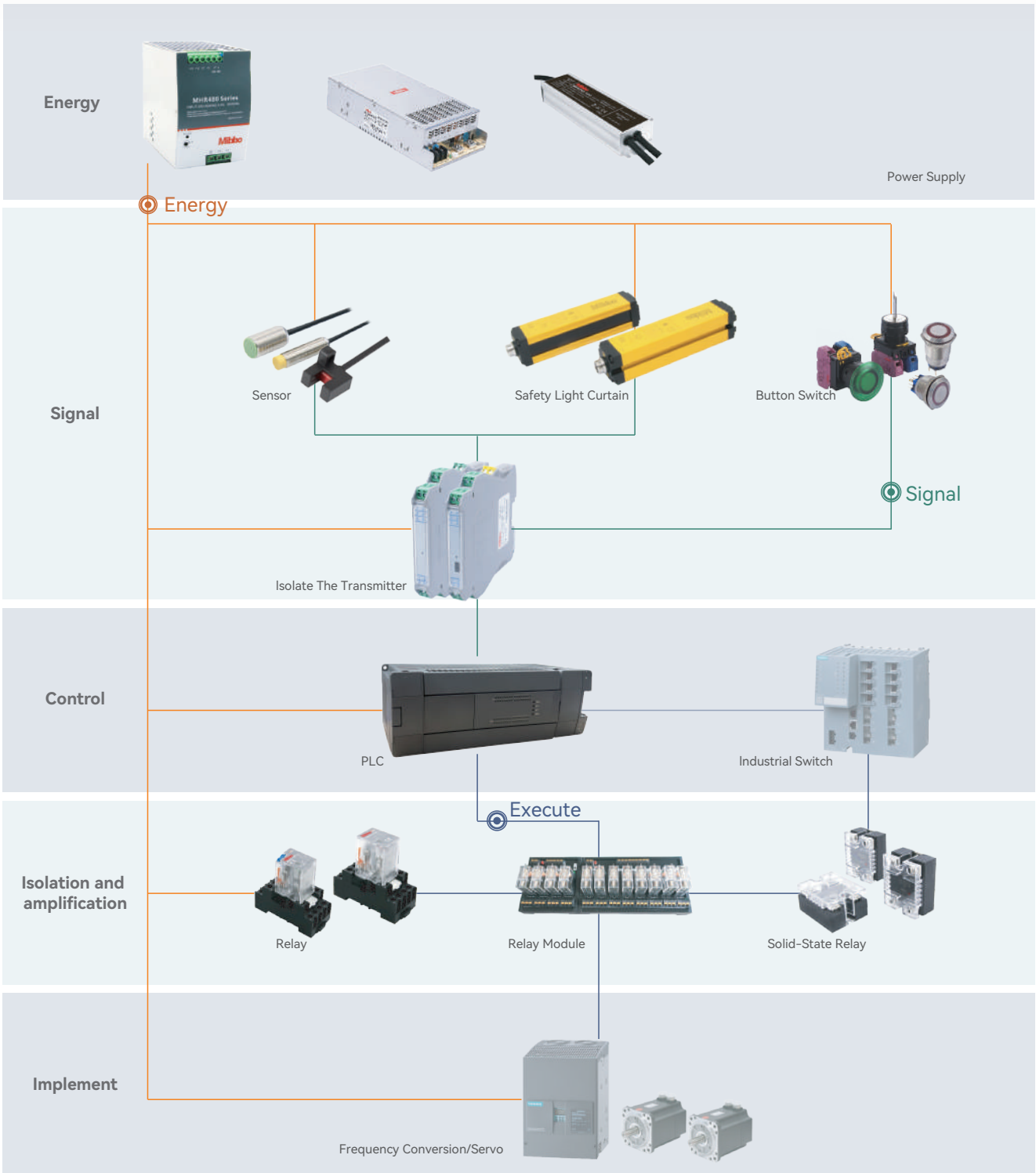



CONTENTS

IUS Series Intelligent Subminiature Cylindrical Proximity Switch	2
IY Series Cylindrical Proximity Switch	3
IYK Series Anti-interference Cylindrical Proximity Switch	3
IYD Series Long Distance Cylindrical Proximity Switch	4-5
IYV2 Series I/O Short Cylindrical Proximity Switch	6
IYV3 Series I/O General Cylindrical Proximity Switch	7
IYV5 Series I/O Long Distance Cylindrical Proximity Switch	8
IYL Series DC 2-Wire Cylindrical Proximity Switch	9
IYLD Series DC 2-Wire Long Distance Cylindrical Proximity Switch	10
IYA Series AC 2-Wire Cylindrical Proximity Switch	11
IYAD Series AC 2-Wire Long Distance Cylindrical Proximity Switch	12
IM Series Small Diameter Cylindrical Proximity Switch	13
IMD Series Long Distance Small Diameter Cylindrical Proximity Switch	14
IS Series Small Diameter Cylindrical Proximity Switch	15
ISD Series Long Distance Small Diameter Cylindrical Proximity Switch	16
ISV Series I/O General Small Diameter Cylindrical Proximity Switch	17
IPE Series Ultra Small Size Rectangular Proximity Switch	18
IP2 Series Rectangular Proximity Switch	19
IP3 Series Intelligent Rectangular Proximity Switch	20
IGA Series Ring shape Proximity Switch	21
IH2 Series Plastic Capacitive Proximity Switch	22
IH4 Series Long Distance Plastic Capacitive Proximity Switch	23
IH3 Series Brass housing Capacitive Proximity Switch	24
IH5 Series Long Distance Brass Capacitive Proximity Switch	25
IHV3 Series I/O Capacitive Proximity Switch	26
IHV5 Series I/O Long Distance Capacitive Proximity Switch	27
PW25 Series Small Size Slot-type Photoelectric Sensor	28
PW45 Series Slot-type Photoelectric Sensor	29
PW67 Series Slot-type Photoelectric Sensor	30
PW34/35/36 Series Slot-type Photoelectric Sensor	31
PBN Series Infrared Cylindrical Photoelectric Sensor	32-33
PBL Series laser Cylindrical Photoelectric Sensor	34-36
PC22 Series Infrared Rectangular Photoelectric Sensor	37
PC27 Series laser Rectangular Photoelectric Sensor	38
PC31/ PC32 Series Red LED Large Rectangular Photoelectric Sensor	39
PCD Series Ultra Small Rectangular Photoelectric Sensor	40
PY Series Background Suppression Photoelectric Sensor	40
PE Series Level Detect Photoelectric Sensor	41
PTX Series Fiber Sensor	42-44
PM Series Safety Light Curtains	45-48

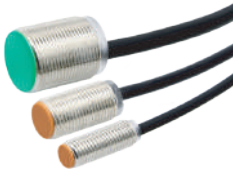

- Features
 - The shortest cylindrical sensor(24mm length)
 - Application in precision and space limited equipment
 - Intelligently identifying NPN/PNP load
 - 3 state indicator: Green-standby, Red-operating, Flash-fault
 - NO/NC output model distinguished by different color. Prevent wiring error
 - Anti-interference design suitable for side-by-side installation and electric-magnetic environment
 - Oil-resistance cable suitable for application in oily environment.
 - Standard cable length 2M, other length cable available.

IUS	12	-	02	A	F	02
Series	Size		Sensing Distance	Output Mode	Shielding	Connection Method
IUS Series	08:M08 12:M12 18:M18		02:2mm 04:4mm 08:8mm	A:NO B:NC	F:Shielded N:Unshielded	Non:2M 01:1M 2R5:2.5M 03:3M

Model			
NO	IUS08-01AF	IUS12-02AF	IUS18-05AF
NC	IUS08-01BF	IUS12-02BF	IUS18-05BF

Specification	
Size	M8 M12 M18
Shielding	Shielded Shielded Shielded
Sensing Distance ①	1.5mm 2mm 5mm
Set Distance	0~1.2mm 0~1.6mm 0~4.0mm
Differential Travel	10% Max. of sensing distance
Detectable Object	Ferrous Metal (The sensing distance decreases with non-ferrous metal. Refer to Data sheet)
Response Frequency②	1000Hz
Power Supply Voltage (Operating Voltage Range)	12-24VDC, Ripple(p-p) 10% Max. (10-30DC full wave rectifier power supply)
Current Consumption	Max.5mA@NPN; Max.7mA@PNP
Load Current	Max.100mA
Residual Voltage	Max.1.5V
Indicators	Green-standby, Red-operating, Flash-fault
Operation Mode	A-Model: NPN+PNP NO; B-Model: NPN+PNP NC
Short Circuit Protection	Overload / load short circuit protection. Indicator flashing in protection state.
Protection Circuit	Polarity protection, Surge suppressor
Ambient Temperature Range	Operating / storage: -30~+70°C (with no icing or condensation)
Ambient Humidity Range	Operating / storage: 35~95% (with no condensation)
Temperature Influence	±10% Max. of sensing distance @+25°C in the temperature range
Voltage Influence	±1% Max. of sensing distance @rated voltage in the rated voltage ±10% range
Anti-interference	Strong anti-magnetic interference
Insulation Resistance	50MΩ Min. (at 500VDC) between current carrying parts and case
Dielectric Strength	1000VAC 50/60Hz for 1 minute between current carrying parts and case
Vibration Resistance	10-55Hz 1.5mm double amplitude for 2 hours each in X,Y,Z directions
Shock Resistance	500m/S ² 10 times each in X, Y and Z directions
Degree of Protection	IEC standards IP67, in-house standards: oil-resistance
Connection Method	Pre-wired 2m
Materials of Case	Nickel-plated brass
Accessories	Clamping nuts. Mounting bracket available(optional)
Certificate	CE

① Sensing distance, range ±10%.
 ② Response frequency is an average value. Measure condition is as follow: standard sensing object, a setting distance of half the sensing distance.
 ③ Recommended app&cation within the setting distance as to reach the best detect effect.

Dimension Diagram Unit: mm

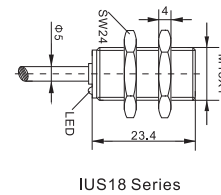
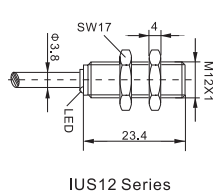
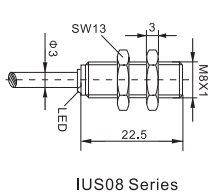

Wiring Diagram

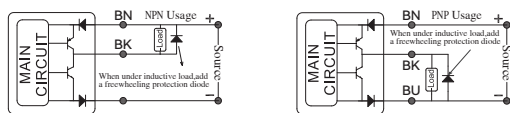



- Features
 - Innovative products. Identifying operating or standby state easily.
 - Applications in precision and space limited equipment
 - 3 state indicator: Green-standby, Red-operating, Flash-fault
 - NO/NC output model distinguished by different color.
 - Prevent wiring error
 - Anti-interference design suitable for side-by-side installation and electric-magnetic environment
 - Oil-resistance cable suitable for application in oily environment.
 - Flexible cable sleeve reduce the risk of disconnection in application with moving parts
 - Standard cable length 2M, other length cable available.

IY	12	-	02	NA	F	V
Series IY Series	Size 08: M08 12: M12 18: M18 30: M30		Sensing Distance 01: 1mm 02: 2mm	Output Mode NA: NPN NO NB: NPN NC PA: PNP NO PB: PNP NC	Shielding F: Shielded N: Unshielded	Plug-in connection

Model (IY Series 3 state high performance cylindrical proximity switch)

NPN NO	IY08-01NAF	IY08-02NAN	IY12-02NAF	IY12-04NAN	IY18-05NAF	IY18-08NAN	IY30-10NAF	IY30-15NAN
NPN NC	IY08-01NBF	IY08-02NBN	IY12-02NBF	IY12-04NBN	IY18-05NBF	IY18-08NBN	IY30-10NBF	IY30-15NBN
PNP NO	IY08-01PAF	IY08-02PAN	IY12-02PAF	IY12-04PAN	IY18-05PAF	IY18-08PAN	IY30-10PAF	IY30-15PAN
PNP NC	IY08-01PBF	IY08-02PBN	IY12-02PBF	IY12-04PBN	IY18-05PBF	IY18-08PBN	IY30-10PBF	IY30-15PBN

Model (IY Series 3 state QD cylindrical proximity switch)

Body (excluding connectors)	NPN NO	IY08-01NAF-V	IY08-02NAN-V	IY12-02NAF-V	IY12-04NAN-V	IY18-05NAF-V	IY18-08NAN-V	IY30-10NAF-V	IY30-15NAN-V
	NPN NC	IY08-01NBF-V	IY08-02NBN-V	IY12-02NBF-V	IY12-04NBN-V	IY18-05NBF-V	IY18-08NBN-V	IY30-10NBF-V	IY30-15NBN-V
	PNP NO	IY08-01PAF-V	IY08-02PAN-V	IY12-02PAF-V	IY12-04PAN-V	IY18-05PAF-V	IY18-08PAN-V	IY30-10PAF-V	IY30-15PAN-V
	PNP NC	IY08-01PBF-V	IY08-02PBN-V	IY12-02PBF-V	IY12-04PBN-V	IY18-05PBF-V	IY18-08PBN-V	IY30-10PBF-V	IY30-15PBN-V

Cable with QD12 connector: P02-F083A2/P02-F083S2(choosable)

P02-F124A2/P02-F124S2(choosable)

Model (IY Series anti-interference cylindrical proximity switch)

NPN NO	IY08-01NAF	IY08-02NAN	IY12-02NAF	IY12-04NAN	IY18-05NAF	IY18-08NAN
NPN NC	IY08-01NBF	IY08-02NBN	IY12-02NBF	IY12-04NBN	IY18-05NBF	IY18-08NBN
PNP NO	IY08-01PAF	IY08-02PAN	IY12-02PAF	IY12-04PAN	IY18-05PAF	IY18-08PAN
PNP NC	IY08-01PBF	IY08-02PBN	IY12-02PBF	IY12-04PBN	IY18-05PBF	IY18-08PBN

Specification

Size	M8		M12		M18		M18	
Shielding	Shielded	Unshielded	Shielded	Unshielded	Shielded	Unshielded	Shielded	Unshielded
Sensing Distance ①	1.5mm	2mm	2mm	4mm	5mm	8mm	10mm	15mm
Set Distance	0~1.2mm	0~1.6mm	0~1.6mm	0~3.2mm	0~4.0mm	0~6.4mm	0~8.0mm	0.1~12mm
Differential Travel	10% Max. of sensing distance							
Detectable Object	Ferrous Metal (The sensing distance decreases with non-ferrous metal. Refer to Data sheet)							
Response Frequency ②	1000Hz							
Power Supply Voltage (Operating Voltage Range)	12-24VDC, Ripple(p-p) 10% Max. (10-30DC full wave rectifier power supply)							
Current Consumption	Max.5mA@NPN; Max.7mA@PNP							
Load Current	Max.100mA							
Residual Voltage	Max.1.5V							
Indicators	Green-standby, Red-operating, Flash-fault							
Operation Mode	A-Model: NPN NO; NB-Model: NPN NC; PA-Model: PNP NO; PB-Model: PNP NC;							
Short Circuit Protection	Overload / load short circuit protection. Indicator flashing in protection state.							
Protection Circuit	Polarity protection, Surge suppressor							
Ambient Temperature Range	Operating / storage: -30~+70°C (with no icing or condensation)							
Ambient Humidity Range	Operating / storage: 35~95% (with no condensation)							
Temperature Influence	±10% Max. of sensing distance @+25°C in the temperature range							
Voltage Influence	±1% Max. of sensing distance @rated voltage in the rated voltage ±10% range							
Anti-interference	IYK Series Strong anti-magnetic interference							
Insulation Resistance	50MΩ Min. (at 500VDC) between current carrying parts and case							
Dielectric Strength	1000VAC 50/60Hz for 1 minute between current carrying parts and case							
Vibration Resistance	10-55Hz 1.5mm double amplitude for 2 hours each in X,Y,Z directions							
Shock Resistance	500m/S ² 10 times each in X, Y and Z directions							
Degree of Protection	IEC standards IP67, in-house standards: oil-resistance							
Connection Method	Pre-wired 2m							
Materials of Case	Nickel-plated brass							
Accessories	Clamping nuts. Mounting bracket available(optional)							
Certificate	CE							

① Sensing distance, range ±10%. ② Response frequency is an average value. Measure condition is as follow: standard sensing object, a setting distance of half the sensing distance.
③ Recommended app&cation within the setting distance as to reach the best detect effect. ④ SFA-QD12A-02 cable needs to purchase separately.

Dimension Diagram

Unit: mm

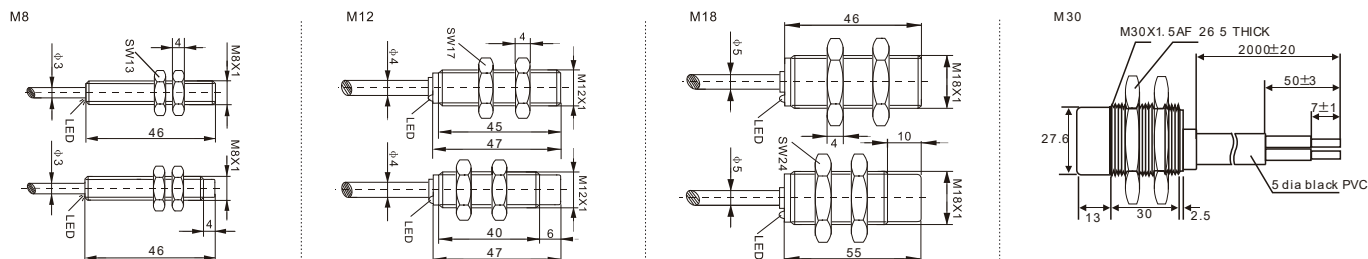

Wiring Diagram

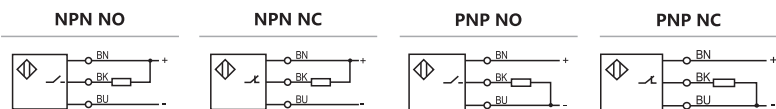

IYD Series Long Distance Cylindrical Proximity Switch



- Features
 - Easy for connection, installation and application
 - High response frequency
 - Protections: Overload/Short circuit
 - Flexible cable
 - Degree of protection: IP67
 - Ambient temperature: -25~+70°C

IYD	12	-	04	NA	F
Series IYD Series	Size 08:M08 12:M12 18:M18 30:M30		Sensing Distance 02:2mm 03:3mm 04:4mm 06:6mm 08:8mm 12:12mm 16:16mm 22:22mm 25:25mm 40:40mm	Output Mode NA:NPN NO NB:NPN NC PA:PNP NO PB:PNP NC	Shielding F:Shielded N:Unshielded

Model	IYD08-02NAF	IYD08-03NAF	IYD08-04NAN	IYD08-06NAN	IYD12-04NAF	IYD12-06NAF	IYD12-08NAN	IYD12-10NAN
NPN NO	IYD08-02NBF	IYD08-03NBF	IYD08-02NBN	IYD08-06NBN	IYD12-04NBF	IYD12-06NBF	IYD12-08NBN	IYD12-10NBN
NPN NC	IYD08-02PAF	IYD08-03PAF	IYD08-02PAN	IYD08-06PAN	IYD12-04PAF	IYD12-06PAF	IYD12-08PAN	IYD12-10PAN
PNP NO	IYD08-02PBF	IYD08-03PBF	IYD08-02PBN	IYD08-06PBN	IYD12-04PBF	IYD12-06PBF	IYD12-08PBN	IYD12-10PBN
PNP NC								

Specification	2mm	3mm	4mm	6mm	4mm	6mm	8mm	10mm
Sensing Distance ①	0~1.6mm	0~2.4mm	0~3.2mm	0~4.8mm	0~3.2mm	0~4.8mm	0~6.4mm	0~8.0mm
Set Distance	8×8×1mm Ferrous metal	8×8×1mm Ferrous metal	8×8×1mm Ferrous metal	12×12×1mm Ferrous metal	12×12×1mm Ferrous metal	12×12×1mm Ferrous metal	12×12×1mm Ferrous metal	12×12×1mm Ferrous metal
Standard Sensing Object	800Hz	800Hz	800Hz	800Hz	800Hz	800Hz	800Hz	800Hz
Response Frequency ②	1.2ms	1.25ms	1.25ms	1.25ms	1.25ms	1.25ms	1.25ms	1.25ms
Response Time	10% Max. of sensing distance							
Differential Travel	Ferrous Metal (The sensing distance decreases with non-ferrous metal. Refer to Data sheet)							
Detectable Object	12-24VDC, Ripple(p-p) 10% Max. (10-30DC full wave rectifier power supply)							
Power Supply Voltage (Operating Voltage Range)	Max.5mA@NPN; Max.7mA@PNP							
Current Consumption	Max.100mA							
Load Current	Max.1.5V							
Residual Voltage	<0.01mA							
Leakage Current	Red(NPN), Orange(PNP)							
Indicators	NA-Model: NPN NO, NB-Model: NPN NC, PA-Model: PNP NO, PB-Model: PNP NC							
Operation Mode	20mA Max.(30VDC Max.)							
Short Circuit Protection	Reverse Polarity protection, Surge suppressor							
Protection Circuit	Operating / storage: -30~+70°C (with no icing or condensation)							
Ambient Temperature Range	Operating / storage: 35-95% (with no condensation)							
Ambient Humidity Range	±10% Max. of sensing distance @+25°C in the temperature range							
Temperature Influence	50MΩ Min. (at 500VDC) between current carrying parts and case							
Insulation Resistance	1000VAC 50/60Hz for 1 minute between current carrying parts and case							
Dielectric Strength	10-55Hz 1.5mm double amplitude for 2 hours each in X,Y,Z directions / 500m/S ² 10 times each in X, Y and Z directions							
Vibration/Shock Resistance	IEC standards IP67, in-house standards: oil-resistance							
Degree of Protection	Pre-wired 2m (customized cable length available)							
Connection Method	Nickel-plated brass							
Materials of Case	PBT							
Materials of Sensing Surface	Clamping nuts. Mounting bracket available(optional)							
Accessories								

① Sensing distance, range ±10%. ② Response frequency is an average value. Measure condition is as follow: standard sensing object, a setting distance of half the sensing distance.
 ③ Recommended app&cation within the setting distance as to reach the best detect effect.

Dimension Diagram Unit: mm

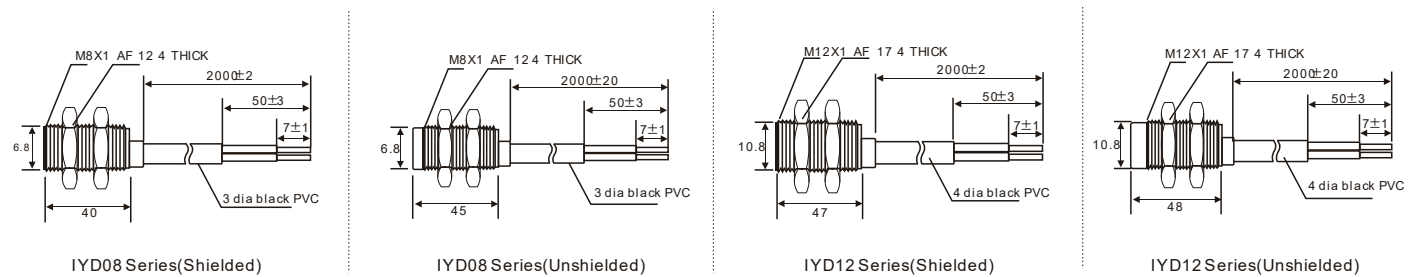

Wiring Diagram





- Features
 - Easy for connection, installation and application
 - High response frequency
 - Protections: Overload/Short circuit
 - Flexible cable
 - Degree of protection: IP67
 - Ambient temperature: -25~+70°C

IYD	18	-	04	NA	F
Series IYD Series	Size 08:M08 12:M12 18:M18 30:M30		Sensing Distance 02:2mm 03:3mm 04:4mm 06:6mm 08:8mm 12:12mm 16:16mm 22:22mm 25:25mm 40:40mm	Output Mode NA:NPN NO NB:NPN NC PA:PNP NO PB:PNP NC	Shielding F:Shielded N:Unshielded

Model	IYD18-08NAF	IYD18-12NAF	IYD18-12NAN	IYD18-16NAN	IYD30-16NAF	IYD30-22NAF	IYD30-25NAN	IYD30-40NAN
NPN NO	IYD18-08NBF	IYD18-12NBF	IYD18-12NBN	IYD18-16NBN	IYD30-16NBF	IYD30-22NBF	IYD30-25NBN	IYD30-40NBN
PNP NO	IYD18-08PAF	IYD18-12PAF	IYD18-12PAN	IYD18-16PAN	IYD30-16PAF	IYD30-22PAF	IYD30-25PAN	IYD30-40PAN
PNP NC	IYD18-08PBF	IYD18-12PBF	IYD18-12PBN	IYD18-16PBN	IYD30-16PBF	IYD30-22PBF	IYD30-25PBN	IYD30-40PBN

Specification	8mm	12mm	12mm	16mm	16mm	22mm	25mm	40mm
Sensing Distance ①	8mm	12mm	12mm	16mm	16mm	22mm	25mm	40mm
Set Distance	0~6.4mm	0~9.6mm	0~9.6mm	0~12.8mm	0~12.8mm	0~17.6mm	0~20mm	0~32mm
Standard Sensing Object	18×18×1mm Ferrous metal		18×18×1mm Ferrous metal		30×30×1mm Ferrous metal		30×30×1mm Ferrous metal	
Response Frequency ②	500Hz	500Hz	500Hz	500Hz	150Hz	150Hz	100Hz	100Hz
Response Time	2ms	2ms	2ms	2ms	6.7ms	6.7ms	10ms	10ms
Differential Travel	10% Max. of sensing distance							
Detectable Object	Ferrous Metal (The sensing distance decreases with non-ferrous metal. Refer to Data sheet)							
Power Supply Voltage (Operating Voltage Range)	12-24VDC, Ripple(p-p) 10% Max. (10-30DC full wave rectifier power supply)							
Current Consumption	Max.5mA@NPN; Max.7mA@PNP							
Load Current	Max.100mA							
Residual Voltage	Max.1.5V							
Leakage Current	0.01mA Max. when 24VDC							
Indicators	Red(NPN), Orange(PNP)							
Operation Mode	NA-Model: NPN NO, NB-Model: NPN NC, PA-Model: PNP NO, PB-Model: PNP NC							
Short Circuit Protection	20mA Max.(30VDC Max.)							
Protection Circuit	Reverse Polarity protection, Surge suppressor							
Ambient Temperature Range	Operating / storage: -30~+70°C (with no icing or condensation)							
Ambient Humidity Range	Operating / storage: 35-95% (with no condensation)							
Temperature Influence	±10% Max. of sensing distance @+25°C in the temperature range							
Insulation Resistance	50MΩ Min. (at 500VDC) between current carrying parts and case							
Dielectric Strength	1000VAC 50/60Hz for 1 minute between current carrying parts and case							
Vibration/Shock Resistance	10-55Hz 1.5mm double amplitude for 2 hours each in X,Y,Z directions / 500m/S ² 10 times each in X, Y and Z directions							
Degree of Protection	IEC standards IP67, in-house standards: oil-resistance							
Connection Method	Pre-wired 2m (customized cable length available)							
Materials of Case	Nickel-plated brass							
Materials of Sensing Surface	PBT							
Accessories	Clamping nuts. Mounting bracket available(optional)							

① Sensing distance, range ±10%. ② Response frequency is an average value. Measure condition is as follow: standard sensing object, a setting distance of half the sensing distance.
 ③ Recommended application within the setting distance as to reach the best detect effect.

Dimension Diagram Unit: mm

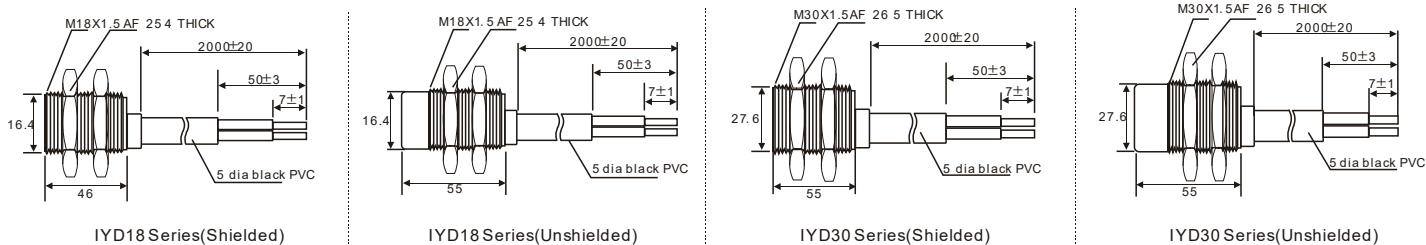

Wiring Diagram



IYV2 Series I/O Short Cylindrical Proximity Switch



- **Features**
 - Easy for connection, installation and application
 - High response frequency
 - Protections: Overload/Short circuit
 - Flexible cable
 - Degree of protection: IP67
 - Ambient temperature: -25~+70°C

IYV2	12	B	-	02	NA	F
Series IYV2 Series	Size 08:M08 12:M12 18:M18	Connector Size A:M8 Connector Size B:M12 Connector Size		Sensing Distance 02:2mm 04:4mm 08:8mm	Output Mode NA:NPN NO NB:NPN NC PA:PNP NO PB:PNP NC	Shielding F:Shielded N:Unshielded

Model								
NPN NO	IYV208□-01NAF ^③	IYV208□-02NAN	IYV212B-02NAF	IYV212B-04NAN	IYV218B-05NAF	IYV218B-08NAN	IYV230B-10NAF	IYV230B-15NAN
NPN NC	IYV208□-01NBF	IYV208□-02NBN	IYD212B-02NBF	IYV212B-04NBN	IYV218B-05NBF	IYV218B-08NBN	IYV230B-10NBF	IYV230B-15NBN
PNP NO	IYV208□-01PAF	IYV208□-02PAN	IYV212B-02PAF	IYV212B-04PAN	IYV218B-05PAF	IYV218B-08PAN	IYV230B-10PAF	IYV230B-15PAN
PNP NC	IYV208□-01PBF	IYV208□-02PBN	IYV212B-02PBF	IYV212B-04PBN	IYV218B-05PBF	IYV218B-08PBN	IYV230B-10PBF	IYV230B-15PBN
Connecting Line	P02-F083A2/P02-F083S2			P02-F124A2/P02-F124S2				

Specification								
Sensing Distance ^①	8mm	12mm	12mm	16mm	16mm	22mm	25mm	40mm
Set Distance	0~6.4mm	0~9.6mm	0~9.6mm	0~12.8mm	0~12.8mm	0~17.6mm	0~20mm	0~32mm
Standard Sensing Object	18×18×1mm Ferrous metal		18×18×1mm Ferrous metal		30×30×1mm Ferrous metal		30×30×1mm Ferrous metal	
Response Frequency ^②	500Hz	500Hz	500Hz	500Hz	150Hz	150Hz	100Hz	100Hz
Response Time	2ms	2ms	2ms	2ms	6.7ms	6.7ms	10ms	10ms
Differential Travel	15% Max. of sensing distance							
Detectable Object	Ferrous Metal (The sensing distance decreases with non-ferrous metal. Refer to Data sheet)							
Power Supply Voltage (Operating Voltage Range)	12-24VDC, Ripple(p-p) 10% Max. (10-30DC full wave rectifier power supply)							
Current Consumption	10mA Max. @24VDC							
Load Current	Max.150mA							
Residual Voltage	1.5V Max. @150mA load and 2M cable							
Leakage Current	0.01mA Max. when 24VDC							
Indicators	Red							
Operation Mode	A-Model: NO, B-Model: NC.							
Short Circuit Protection	≥180mA							
Protection Circuit	Reverse Polarity protection, Surge suppressor							
Ambient Temperature Range	Operating / storage: -25~+70°C (with no icing or condensation)							
Ambient Humidity Range	Operating / storage: 35-95% (with no condensation)							
Temperature Influence	±10% Max. of sensing distance @+25°C in the temperature range							
Insulation Resistance	50MΩ Min. (at 500VDC) between current carrying parts and case							
Dielectric Strength	1000VAC 50/60Hz for 1 minute between current carrying parts and case							
Vibration/Shock Resistance	IEC 60947-5-2, Part7.4.1 / IEC 60947-5-2, Part7.4.2							
EMC	RFI>3V/M / EFT>1KV / ESD>4KV(contact)							
Degree of Protection	IEC standards EN60529:IP67							
Connection Method	Connector (M12 4-pin). For IYV208A series (M8 3-pin)							
Weight (Packed state)	~28g	~30g	~45g	~50g	~70g	~80g	~110g	~120g
Materials of Case	Nickel-plated brass							
Materials of Sensing Surface	PBT							
Accessories	Clamping nuts. Mounting bracket available(optional)							

① Sensing distance, range ±10%. ② Response frequency is an average value. Measure condition is as follow: standard sensing object, a setting distance of half the sensing distance.
③ □ for different connector: A – M8 connector, B – M12 connector

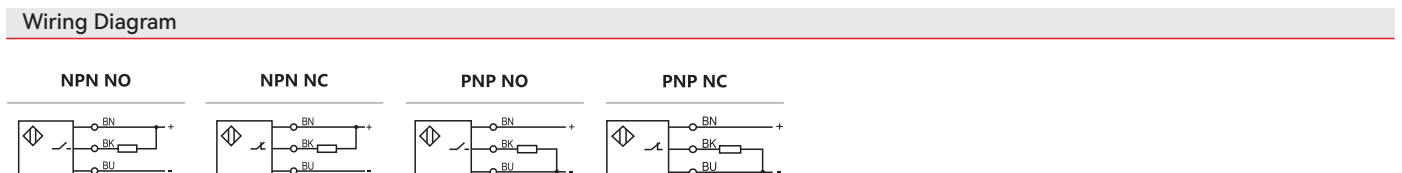
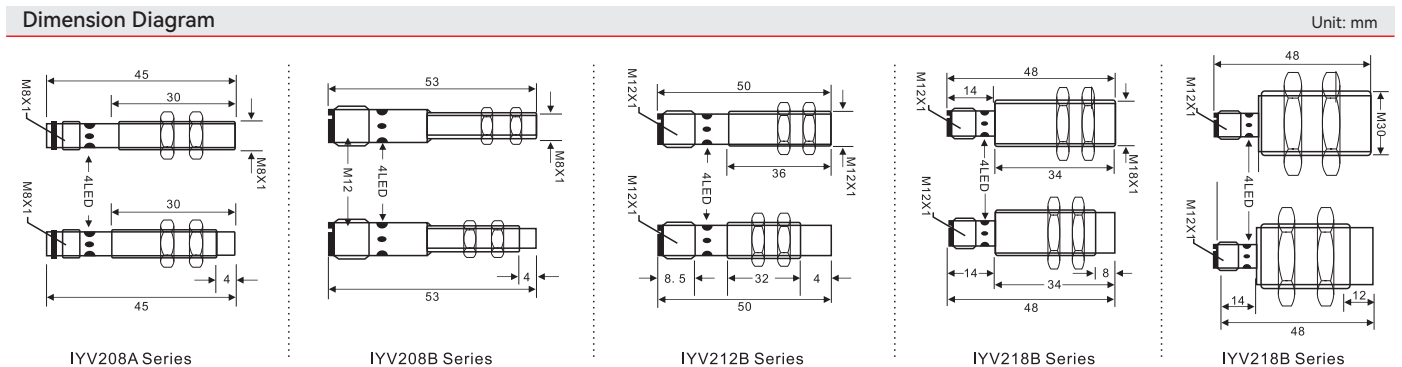



- Features
 - Easy for connection, installation and application
 - High response frequency
 - Protections: Overload/Short circuit
 - Flexible cable
 - Degree of protection: IP67
 - Ambient temperature: -25~+70°C

IYV3	12	B	-	02	NA	F
Series IYV3 Series	Size 08:M08 12:M12 18:M18 30:M30	Connector Size A:M8 Connector Size B:M12 Connector Size		Sensing Distance 02:2mm 03:3mm 08:8mm	Output Mode NA:NPN NO NB:NPN NC PA:PNP NO PB:PNP NC	Shielding F:Shielded N:Unshielded

Model								
NPN NO	IYV308□-01NAF ^③	IYV308□-02NAN	IYV312B-02NAF	IYV312B-04NAN	IYV318B-05NAF	IYV318B-08NAN	IYV330B-10NAF	IYV330B-15NAN
NPN NC	IYV308□-01NBF	IYV308□-02NBN	IYD312B-02NBF	IYV312B-04NBN	IYV318B-05NBF	IYV318B-08NBN	IYV330B-10NBF	IYV330B-15NBN
PNP NO	IYV308□-01PAF	IYV308□-02PAN	IYV312B-02PAF	IYV312B-04PAN	IYV318B-05PAF	IYV318B-08PAN	IYV330B-10PAF	IYV330B-15PAN
PNP NC	IYV308□-01PBF	IYV308□-02PBN	IYV312B-02PBF	IYV312B-04PBN	IYV318B-05PBF	IYV318B-08PBN	IYV330B-10PBF	IYV330B-15PBN

Specification								
Sensing Distance ^①	1mm	2mm	2mm	4mm	5mm	8mm	10mm	15mm
Set Distance	0~0.8mm	0~1.6mm	0~1.6mm	0~3.2mm	0~4mm	0~6.4mm	0~8mm	0~12mm
Standard Sensing Object	8×8×1mm Ferrous metal		12×12×1mm Ferrous metal		18×18×1mm Ferrous metal		30×30×1mm Ferrous metal	
Response Frequency ^②	2KHz	2KHz	2KHz	1KHz	1KHz	500Hz	300Hz	150Hz
Response Time	0.1ms	0.1ms	0.1ms	0.2ms	0.5ms	0.5ms	0.5ms	0.5ms
Differential Travel	15% Max. of sensing distance							
Detectable Object	Ferrous Metal (The sensing distance decreases with non-ferrous metal. Refer to Data sheet)							
Power Supply Voltage (Operating Voltage Range)	12-24VDC, Ripple(p-p) 10% Max. (10-30DC full wave rectifier power supply)							
Current Consumption	10mA Max. @24VDC							
Load Current	Max.150mA							
Residual Voltage	1.5V Max. @150mA load and 2M cable							
Leakage Current	0.01mA Max. when 24VDC							
Indicators	Red							
Operation Mode	A-Model: NO, B-Model: NC.							
Short Circuit Protection	≥180mA							
Protection Circuit	Reverse Polarity protection, Surge suppressor							
Ambient Temperature Range	Operating / storage: -25~+70°C (with no icing or condensation)							
Ambient Humidity Range	Operating / storage: 35-95% (with no condensation)							
Temperature Influence	±10% Max. of sensing distance @+25°C in the temperature range							
Insulation Resistance	50MΩ Min. (at 500VDC) between current carrying parts and case							
Dielectric Strength	1000VAC 50/60Hz for 1 minute between current carrying parts and case							
Vibration/Shock Resistance	IEC 60947-5-2, Part7.4.1 / IEC 60947-5-2, Part7.4.2							
EMC	RFI>3V/M / EFT>1KV / ESD>4KV(contact)							
Degree of Protection	IEC standards EN60529:IP67							
Connection Method	Connector (M12 4-pin). For IYV208A series (M8 3-pin)							
Weight (Packed state)	~30g	~32g	~50g	~55g	~80g	~85g	~120g	~130g
Materials of Case	Nickel-plated brass							
Materials of Sensing Surface	PBT							
Accessories	Clamping nuts. Mounting bracket available(optional)							

① Sensing distance, range ±10%. ② Response frequency is an average value. Measure condition is as follow: standard sensing object, a setting distance of half the sensing distance.
③ □ for different connector: A – M8 connector, B – M12 connector

Dimension Diagram Unit: mm

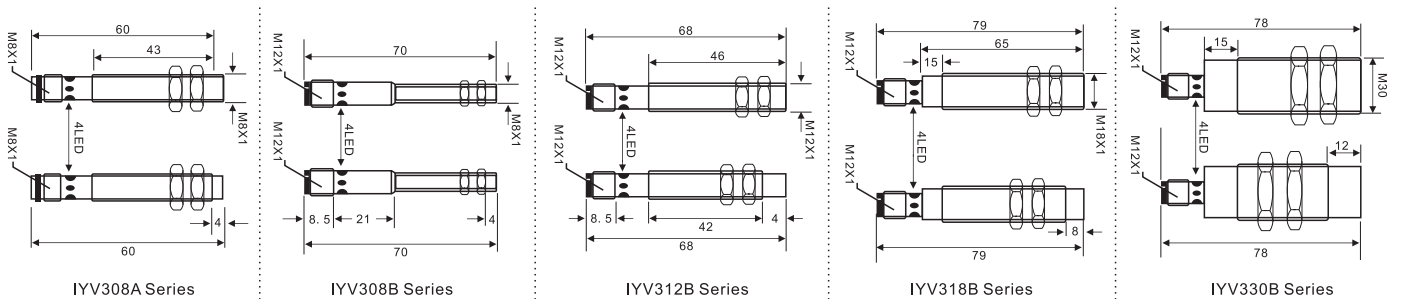

Wiring Diagram



IYV5 Series I/O Long Distance Cylindrical Proximity Switch



Features

- Easy for connection, installation and application
- Super long sensing distance
- Protections: Overload/ Short circuit
- Flexible cable (purchase separately)
- Degree of protection: IP67
- Ambient temperature: -25~+70°C

IYV5	12	B	-	04	NA	F
Series IYV3 Series	Size 08:M08 12:M12 18:M18 30:M30	Connector Size A:M8 Connector Size B:M12 Connector Size		Sensing Distance 02:2mm 04:4mm 08:8mm	Output Mode NA:NPN NO NB:NPN NC PA:PNP NO PB:PNP NC	Shielding F:Shielded N:Unshielded

Model	IYV508□-02NAF ^①	IYV508□-04NAN	IYV512B-04NAF	IYV512B-08NAN	IYV518B-08NAF	IYV518B-12NAN	IYV530B-16NAF	IYV530B-25NAN
NPN NO	IYV508□-02NAF ^①	IYV508□-04NAN	IYV512B-04NAF	IYV512B-08NAN	IYV518B-08NAF	IYV518B-12NAN	IYV530B-16NAF	IYV530B-25NAN
NPN NC	IYV508□-02NBF	IYV508□-04NBN	IYD512B-04NBF	IYV512B-08NBN	IYV518B-08NBF	IYV518B-12NBN	IYV530B-16NBF	IYV530B-25NBN
PNP NO	IYV508□-02PAF	IYV508□-04PAN	IYV512B-04PAF	IYV512B-08PAN	IYV518B-08PAF	IYV518B-12PAN	IYV530B-16PAF	IYV530B-25PAN
PNP NC	IYV508□-02PBF	IYV508□-04PBN	IYV512B-04PBF	IYV512B-08PBN	IYV518B-08PBF	IYV518B-12PBN	IYV530B-16PBF	IYV530B-25PBN
Sensing Distance ^①	2mm	4mm	4mm	8mm	8mm	12mm	16mm	25mm
Set Distance	0~1.6mm	0~3.2mm	0~3.2mm	0~6.4mm	0~6.4mm	0~9.6mm	0~12.8mm	0~12mm
Standard Sensing Object	8×8×1mm Ferrous metal		12×12×1mm Ferrous metal		18×18×1mm Ferrous metal		30×30×1mm Ferrous metal	
Response Frequency ^②	1KHz	800Hz	1KHz	500Hz	500Hz	150Hz	150Hz	100Hz
Response Time	0.1ms	0.2ms	0.2ms	0.5ms	0.5ms	1ms	0.5ms	1ms
Weight (Packed state)	~28g	~30g	~45g	~50g	~70g	~80g	~110g	~120g

Model	IYV508□-03NAF ^①	IYV508□-06NAN	IYV512B-06NAF	IYV512B-10NAN	IYV518B-12NAF	IYV518B-16NAN	IYV530B-22NAF	IYV530B-40NAN
NPN NO	IYV508□-03NAF ^①	IYV508□-06NAN	IYV512B-06NAF	IYV512B-10NAN	IYV518B-12NAF	IYV518B-16NAN	IYV530B-22NAF	IYV530B-40NAN
NPN NC	IYV508□-03NBF	IYV508□-06NBN	IYD512B-06NBF	IYV512B-10NBN	IYV518B-12NBF	IYV518B-16NBN	IYV530B-22NBF	IYV530B-40NBN
PNP NO	IYV508□-03PAF	IYV508□-06PAN	IYV512B-06PAF	IYV512B-10PAN	IYV518B-12PAF	IYV518B-16PAN	IYV530B-22PAF	IYV530B-40PAN
PNP NC	IYV508□-03PBF	IYV508□-06PBN	IYV512B-06PBF	IYV512B-10PBN	IYV518B-12PBF	IYV518B-16PBN	IYV530B-22PBF	IYV530B-40PBN
Sensing Distance ^①	3mm	6mm	6mm	10mm	12mm	16mm	22mm	40mm
Set Distance	0~2.4mm	0~4.8mm	0~4.8mm	0~8mm	0~9.6mm	0~12.8mm	0~17.6mm	0~32mm
Standard Sensing Object	8×8×1mm Ferrous metal		12×12×1mm Ferrous metal		18×18×1mm Ferrous metal		30×30×1mm Ferrous metal	
Response Frequency ^②	500Hz	400Hz	400Hz	300Hz	300Hz	100Hz	150Hz	100Hz
Response Time	0.5ms	1ms	0.5ms	1ms	0.5ms	1ms	0.5ms	1ms
Weight (Packed state)	~28g	~30g	~45g	~50g	~70g	~80g	~110g	~120g
Connecting Line	P02-F083A2/P02-F083S2				P02-F124A2/P02-F124S2			

Specification	
Differential Travel	15% Max. of sensing distance
Detectable Object	Ferrous Metal (The sensing distance decreases with non-ferrous metal. Refer to Data sheet)
Power Supply Voltage (Operating Voltage Range)	12-24VDC, Ripple(p-p) 10% Max. (10-30DC full wave rectifier power supply)
Current Consumption	10mA Max. @24VDC
Load Current	Max.150mA
Residual Voltage	1.5V Max. @150mA load and 2M cable
Leakage Current	0.01mA Max. when 24VDC
Indicators	Red
Operation Mode	NA-Model: NO, NB-Model: NC.
Short Circuit Protection	≥180mA
Protection Circuit	Reverse Polarity protection, Surge suppressor
Ambient Temperature Range	Operating / storage: -25~+70°C (with no icing or condensation)
Ambient Humidity Range	Operating / storage: 35-95% (with no condensation)
Temperature Influence	±10% Max. of sensing distance @+25°C in the temperature range
Insulation Resistance	50MΩ Min. (at 500VDC) between current carrying parts and case
Dielectric Strength	1000VAC 50/60Hz for 1 minute between current carrying parts and case
Vibration/Shock Resistance	IEC 60947-5-2, Part7.4.1 / IEC 60947-5-2, Part7.4.2
EMC	RFI>3V/M / EFT>1KV / ESD>4KV(contact)
Degree of Protection	IEC standards EN60529:IP67
Connection Method	Connector (M12 4-pin). For IYV208A series (M8 3-pin)
Materials of Case	Nickel-plated brass
Materials of Sensing Surface	PBT
Accessories	Clamping nuts. Mounting bracket available(optional)

① Sensing distance, range ±10%. ② Response frequency is an average value. Measure condition is as follow: standard sensing object, a setting distance of half the sensing distance.
 ③ □for different connector: A - M8 connector, B - M12 connector

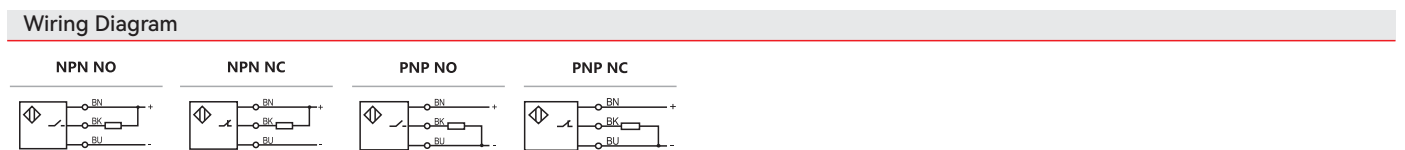
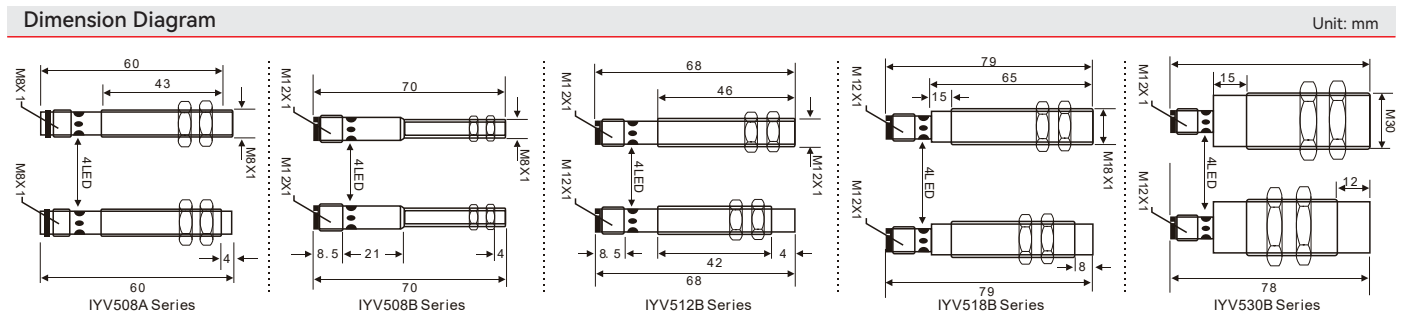



- Features
 - Easy for connection, installation and application
 - Wide input range: 10~60VDC
 - Protections: Overload/ Surge suppressor/ Short circuit
 - Flexible cable
 - Degree of protection: IP67
 - Ambient temperature: -25~+70°C

IYV5	12	-	04	A	N
Series IYL Series	Size 08:M08 12:M12 18:M18 30:M30		Sensing Distance 02:2mm 04:4mm 08:8mm	Output Mode A:NO B:NC	Shielding F:Shielded N:Unshielded

Model								
NO	IYL08-01AF	IYL08-02AN	IYL12-02AF	IYL12-04AN	IYL18-05AF	IYL18-08AN	IYL30-10AF	IYL30-15AN
NC	IYL08-01BF	IYL08-02BN	IYL12-02BF	IYL12-04BN	IYL18-05BF	IYL18-08BN	IYL30-10AF	IYL30-15BN

Specification	1mm	2mm	2mm	4mm	5mm	8mm	10mm	15mm
Sensing Distance ^①	1mm	2mm	2mm	4mm	5mm	8mm	10mm	15mm
Set Distance	0~0.8mm	0~1.6mm	0~1.6mm	0~3.2mm	0~4mm	0~6.4mm	0~8mm	0~12mm
Standard Sensing Object	8×8×1mm Ferrous metal		12×12×1mm Ferrous metal		18×18×1mm Ferrous metal		30×30×1mm Ferrous metal	
Response Frequency ^②	1.2KHz	1.2KHz	300Hz	300Hz	300Hz	300Hz	300Hz	300Hz
Response Time	0.3ms	0.3ms	1.5ms	1.5ms	1.5ms	1.5ms	1.5ms	1.5ms
Differential Travel	15% Max. of sensing distance							
Detectable Object	Ferrous Metal (The sensing distance decreases with non-ferrous metal. Refer to Data sheet)							
Power Supply Voltage (Operating Voltage Range)	10-60VDC, Ripple(p-p) 10% Max. (10-60DC full wave rectifier power supply)							
Load Current	3~100mA							
Residual Voltage	6V Max. @100mA load and 2M cable							
Leakage Current	0.8mA Max. @ 60VDC							
Indicators	Red							
Operation Mode	A-Model: NO, B-Model: NC.							
Short Circuit Protection	≥120mA							
Protection Circuit	Overload/ Surge suppressor/ Short circuit protection							
Ambient Temperature Range	Operating / storage: -25~+70°C (with no icing or condensation)							
Ambient Humidity Range	Operating / storage: 35-95% (with no condensation)							
Temperature Influence	±10% Max. of sensing distance @+25°C in the temperature range							
Insulation Resistance	50MΩ Min. (at 500VDC) between current carrying parts and case							
Dielectric Strength	1000VAC 50/60Hz for 1 minute between current carrying parts and case							
Vibration/Shock Resistance	IEC 60947-5-2,Part7.4.1 / IEC 60947-55-2,Part7.4.2							
EMC	RFI>3V/M / EFT>1KV / ESD>4KV(contact)							
Degree of Protection	IEC standards EN60529:IP67							
Connection Method	Pre-wired 2M							
Weight (Packed state)	~40g	~45g	~65g	~70g	~110g	~120g	~200g	~220g
Materials of Case	Nickel-plated brass							
Materials of Sensing Surface	PBT							
Accessories	Clamping nuts. Mounting bracket available(optional)							

① Sensing distance, range ±10%. ② Response frequency is an average value. Measure condition is as follow: standard sensing object, a setting distance of half the sensing distance.

Dimension Diagram Unit: mm

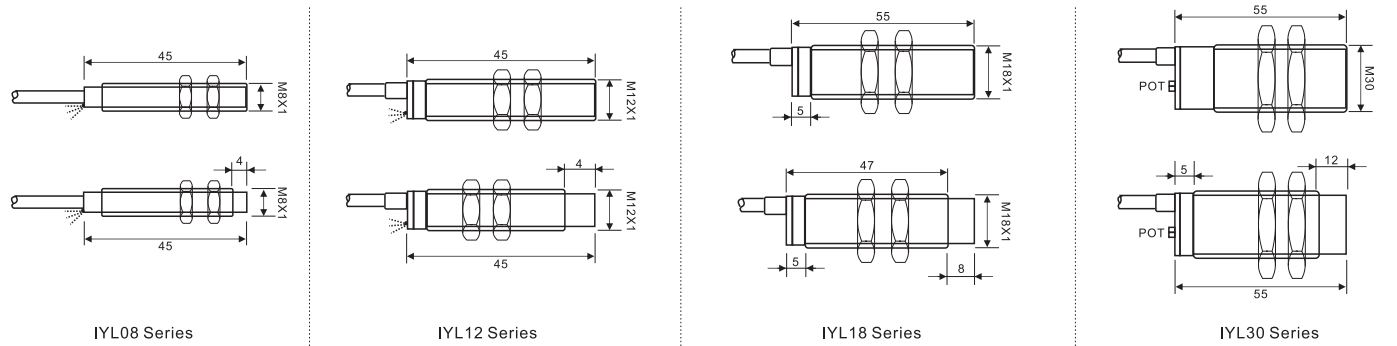

Wiring Diagram

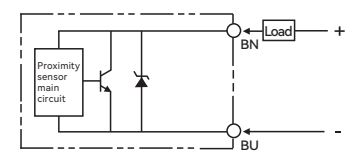

Note: Both the +V and 0V sides can be connected to the load



Features

- Easy for connection, installation and application
- Wide input range: 10~60VDC
- Super long sensing distance
- Protections: Overload/ Surge suppressor/ Short circuit
- Flexible cable
- Degree of protection: IP67
- Ambient temperature: -25~+70°C

IYLD	12	-	08	A	N
Series IYLD Series	Size 08:M08 12:M12 18:M18 30:M30		Sensing Distance 02:2mm 04:4mm 08:8mm	Output Mode A:NO B:NC	Shielding F:Shielded N:Unshielded

Model	IYLD08-02AF	IYLD08-04AN	IYLD12-04AF	IYLD12-08AN	IYLD18-08AF	IYLD18-12AN	IYL30-16AF	IYL30-25AN
NO								
NPN NC								

Specification	2mm	4mm	4mm	8mm	8mm	12mm	16mm	25mm
Sensing Distance ^①	2mm	4mm	4mm	8mm	8mm	12mm	16mm	25mm
Set Distance	0~1.6mm	0~3.2mm	0~3.2mm	0~6.4mm	0~6.4mm	0~9.6mm	0~12.8mm	0~20mm
Standard Sensing Object	8×8×1mm Ferrous metal		12×12×1mm Ferrous metal		18×18×1mm Ferrous metal		30×30×1mm Ferrous metal	
Response Frequency ^②	1KHz	800Hz	100Hz	100Hz	100Hz	100Hz	100Hz	100Hz
Response Time	0.3ms	0.3ms	1.5ms	1.5ms	1.5ms	1.5ms	1.5ms	1.5ms
Differential Travel	15% Max. of sensing distance							
Detectable Object	Ferrous Metal (The sensing distance decreases with non-ferrous metal. Refer to Data sheet)							
Power Supply Voltage (Operating Voltage Range)	10-60VDC, Ripple(p-p) 10% Max. (10-60DC full wave rectifier power supply)							
Load Current	3~100mA							
Residual Voltage	6V Max. @100mA load and 2M cable							
Leakage Current	0.8mA Max. @ 60VDC							
Indicators	Red							
Operation Mode	A-Model: NO, B-Model: NC.							
Short Circuit Protection	≥120mA							
Protection Circuit	Overload/ Surge suppressor/ Short circuit protection							
Ambient Temperature Range	Operating / storage: -25~+70°C (with no icing or condensation)							
Ambient Humidity Range	Operating / storage: 35-95% (with no condensation)							
Temperature Influence	±10% Max. of sensing distance @+25°C in the temperature range							
Insulation Resistance	50MΩ Min. (at 500VDC) between current carrying parts and case							
Dielectric Strength	1000VAC 50/60Hz for 1 minute between current carrying parts and case							
Vibration/Shock Resistance	IEC 60947-5-2, Part7.4.1 / IEC 60947-55-2, Part7.4.2							
EMC	RFI>3V/M / EFT>1KV / ESD>4KV(contact)							
Degree of Protection	IEC standards EN60529:IP67							
Connection Method	Pre-wired 2M							
Weight (Packed state)	~40g	~45g	~65g	~70g	~110g	~120g	~200g	~220g
Materials of Case	Nickel-plated brass							
Materials of Sensing Surface	PBT							
Accessories	Clamping nuts. Mounting bracket available(optional)							

① Sensing distance, range ±10%. ② Response frequency is an average value. Measure condition is as follow: standard sensing object, a setting distance of half the sensing distance.

Dimension Diagram Unit: mm

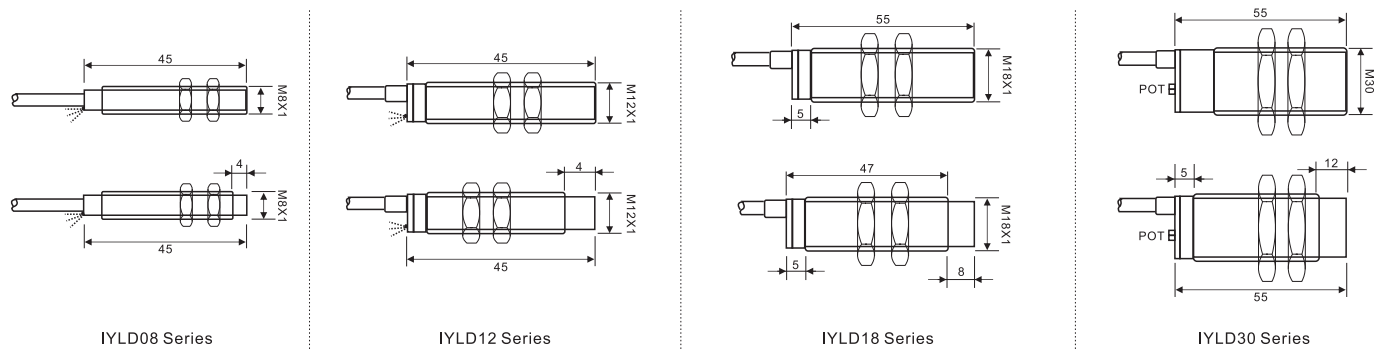

Wiring Diagram

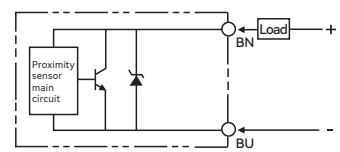

Note: Both the +V and 0V sides can be connected to the load



- Features
 - Easy for connection, installation and application
 - Wide input range: 25~250VAC
 - Overload Protection
 - Flexible cable
 - Degree of protection: IP67
 - Ambient temperature: -25~+70°C

IYA	12	-	04	A	N
Series IYA Series	Size 08:M08 12:M12 18:M18 30:M30		Sensing Distance 02:2mm 04:4mm 08:8mm	Output Mode A:NO B:NC	Shielding F:Shielded N:Unshielded

Model						
NPN NO	IYA12-02AF	IYA12-04AN	IYA18-05AF	IYA18-08AN	IYA30-10AF	IYA30-15AN
NPN NC	IYA12-02BF	IYA12-04BN	IYA18-05BF	IYA18-08BN	IYA30-10BF	IYA30-15BN

Specification						
Sensing Distance ^①	2mm	4mm	4mm	8mm	10mm	15mm
Set Distance	0~1.6mm	0~3.2mm	0~3.2mm	0~6.4mm	0~8mm	0~12mm
Standard Sensing Object	12×12×1mm Ferrous metal		18×18×1mm Ferrous metal		30×30×1mm Ferrous metal	
Response Frequency ^②	<25Hz					
Response Time	10ms					
Differential Travel	15% Max. of sensing distance					
Detectable Object	Ferrous Metal (The sensing distance decreases with non-ferrous metal. Refer to Data sheet)					
Power Supply Voltage (Operating Voltage Range)	25~250VAC 50/60Hz (25~250VAC)					
Current Consumption	1.8mA Max. @250VAC					
Load Current	Max.400mA					
Residual Voltage	8VAC Max. @400mA load and 2M cable					
Leakage Current	1.8mA Max. @ 250VAC					
Indicators	Red					
Operation Mode	A-Model: NO, B-Model: NC.					
Short Circuit Protection	Yes					
Ambient Temperature Range	Operating / storage: -25~+70°C (with no icing or condensation)					
Ambient Humidity Range	Operating / storage: 35-95% (with no condensation)					
Temperature Influence	±10% Max. of sensing distance @+25°C in the temperature range					
Insulation Resistance	50MΩ Min. (at 500VDC) between current carrying parts and case					
Dielectric Strength	1000VAC 50/60Hz for 1 minute between current carrying parts and case					
Vibration/Shock Resistance	IEC 60947-5-2,Part7.4.1 / IEC 60947-55-2,Part7.4.2					
EMC	RFI>3V/M / EFT>1KV / ESD>4KV(contact)					
Degree of Protection	IEC standards EN60529:IP67					
Connection Method	Pre-wired 2M					
Weight (Packed state)	~65g	~70g	~110g	~120g	~200g	~210g
Materials of Case	Nickel-plated brass					
Materials of Sensing Surface	PBT					
Accessories	Clamping nuts. Mounting bracket available(optional)					

① Sensing distance, range ±10%. ② About the voltage waveform: please choose the sine waveform of the power supply, the rectangular wave of the power supply will lead to poor reset.

Dimension Diagram Unit: mm

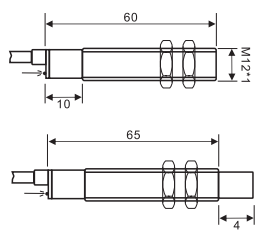

IYA12 Series

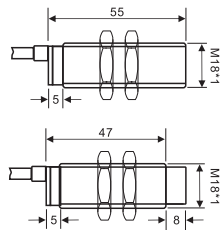

IYA18 Series

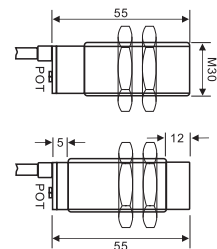

IYA30 Series

Wiring Diagram

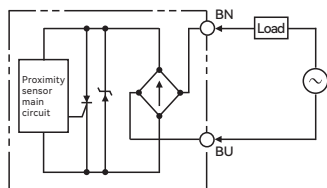

Note: Both the L-side and N-side can be connected to the load



- **Features**
 - Easy for connection, installation and application
 - Wide input range: 25~250VAC
 - Super long sensing distance
 - Overload/ Surge suppressor
 - Flexible cable
 - Degree of protection: IP67
 - Ambient temperature: -25~+70°C

IYAD	12	-	08	A	N
Series	Size		Sensing Distance	Output Mode	Shielding
IYAD Series	08:M08 12:M12 18:M18		02:2mm 04:4mm 08:8mm	A:NO B:NC	F:Shielded N:Unshielded

Model						
NPN NO	IYAD12-04AF	IYAD12-08AN	IYAD18-08AF	IYAD18-16AN	IYAD30-16AF	IYAD30-25AN
NPN NC	IYAD12-04BF	IYAD12-08BN	IYAD18-08BF	IYAD18-16BN	IYAD30-16BF	IYAD30-25BN

Specification						
Sensing Distance ^①	4mm	8mm	8mm	16mm	16mm	25mm
Set Distance	0~3.2mm	0~6.4mm	0~6.4mm	0~12.8mm	0~12.8mm	0~20mm
Standard Sensing Object	12×12×1mm Ferrous metal		18×18×1mm Ferrous metal		30×30×1mm Ferrous metal	
Response Frequency ^②	<25Hz					
Response Time	10ms					
Differential Travel	15% Max. of sensing distance					
Detectable Object	Ferrous Metal (The sensing distance decreases with non-ferrous metal. Refer to Data sheet)					
Power Supply Voltage (Operating Voltage Range)	25~250VAC 50/60Hz (25~250VAC)					
Current Consumption	1.8mA Max. @250VAC					
Load Current	Max.400mA					
Residual Voltage	8VAC Max. @400mA load and 2M cable					
Leakage Current	1.8mA Max. @ 250VAC					
Indicators	Red					
Operation Mode	A-Model: NO, B-Model: NC.					
Short Circuit Protection	Yes					
Ambient Temperature Range	Operating / storage: -25~+70°C (with no icing or condensation)					
Ambient Humidity Range	Operating / storage: 35-95% (with no condensation)					
Temperature Influence	±10% Max. of sensing distance @+25°C in the temperature range					
Insulation Resistance	50MΩ Min. (at 500VDC) between current carrying parts and case					
Dielectric Strength	1000VAC 50/60Hz for 1 minute between current carrying parts and case					
Vibration/Shock Resistance	IEC 60947-5-2, Part7.4.1 / IEC 60947-55-2, Part7.4.2					
EMC	RFI>3V/M / EFT>1KV / ESD>4KV(contact)					
Degree of Protection	IEC standards EN60529:IP67					
Connection Method	Pre-wired 2M					
Weight (Packed state)	~65g	~70g	~110g	~120g	~200g	~210g
Materials of Case	Nickel-plated brass					
Materials of Sensing Surface	PBT					
Accessories	Clamping nuts. Mounting bracket available(optional)					

① Sensing distance, range ±10%. ② About the voltage waveform: please choose the sine waveform of the power supply, the rectangular wave of the power supply will lead to poor reset.

Dimension Diagram Unit: mm

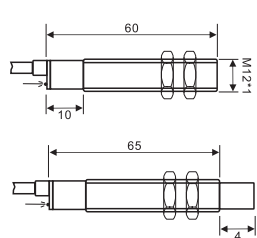

IYAD12 Series

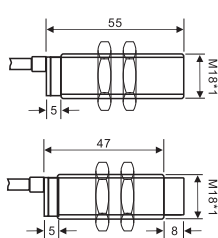

IYAD18 Series

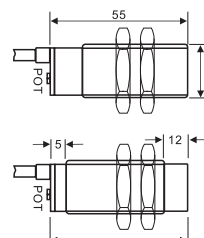

IYAD30 Series

Wiring Diagram

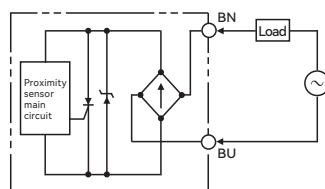

Note: Both the L-side and N-side can be connected to the load



- Features
 - Easy for connection, installation and application
 - High response frequency
 - Stable and reliable
 - Flexible cable
 - Degree of protection: IP67
 - Ambient temperature: -25~+70°C

IM	04	-	R8	NA	F
Series IM Series	Size 04: M4 05: M5 06: M6		Sensing Distance R8: 0.8mm 0.1: 1mm	Output Mode NA: NPN NO NB: NPN NC PA: PNP NO PB: PNP NC	Shielding F: Shielded

Model				
NPN NO	IM04-R8NAF	IM05-01NAF	IM05-01NAF-S ^③	IM06-01NAF
NPN NC	IM04-R8NBF	IM05-01NBF	IM05-01NBF-S	IM06-01NBF
PNP NO	IM04-R8PAF	IM05-01PAF	IM05-01PAF-S	IM06-01PAF
PNP NC	IM04-R8PBF	IM05-01PBF	IM05-01PBF-S	IM06-01PBF

Specification				
Sensing Distance ^①	0.8mm	1mm	1mm	1mm
Set Distance	0~0.64mm	0~0.8mm	0~0.8mm	0~0.8mm
Standard Sensing Object	4×4×1mm Ferrous metal	5×5×1mm Ferrous metal	5×5×1mm Ferrous metal	6×6×1mm Ferrous metal
Response Frequency ^②	2KHz			
Response Time	0.1ms			
Differential Travel	15% Max. of sensing distance			
Detectable Object	Ferrous Metal (The sensing distance decreases with non-ferrous metal. Refer to Data sheet)			
Power Supply Voltage (Operating Voltage Range)	12~24VDC, Ripple(p-p) 10% Max. (10~30DC full wave rectifier power supply)			
Current Consumption	10mA Max. @240VDC			
Load Current	Max.100mA		Max.150mA	
Residual Voltage	1.5V Max. @150mA load and 2M cable			
Leakage Current	0.01mA Max. @ 24VDC			
Indicators	Red			
Operation Mode	NA-Model: NO, NB-Model: NC.			
Short Circuit Protection	—		≥180mA	
Protection Circuit	—		Reverse Polarity protection, Surge suppressor	
Ambient Temperature Range	Operating / storage: -25~+70°C (with no icing or condensation)			
Ambient Humidity Range	Operating / storage: 35-95% (with no condensation)			
Temperature Influence	±10% Max. of sensing distance @+25°C in the temperature range			
Insulation Resistance	50MΩ Min. (at 500VDC) between current carrying parts and case			
Dielectric Strength	1000VAC 50/60Hz for 1 minute between current carrying parts and case			
Vibration/Shock Resistance	IEC 60947-5-2, Part7.4.1 / IEC 60947-5-2, Part7.4.2			
EMC	RFI>3V/M / EFT>1KV / ESD>4KV(contact)			
Degree of Protection	IEC standards EN60529:IP67			
Connection Method	Pre-wired 2M			
Weight (Packed state)	~15g	~20g	~20g	~23g
Materials of Case	Stainless Steel			
Materials of Sensing Surface	PA66			
Accessories	Clamping nuts. Mounting bracket available(optional)			

① Sensing distance, range ±10%. ② Response frequency is an average value. Measure condition is as follow: standard sensing object, a setting distance of half the sensing distance. ③ ?

Dimension Diagram Unit: mm

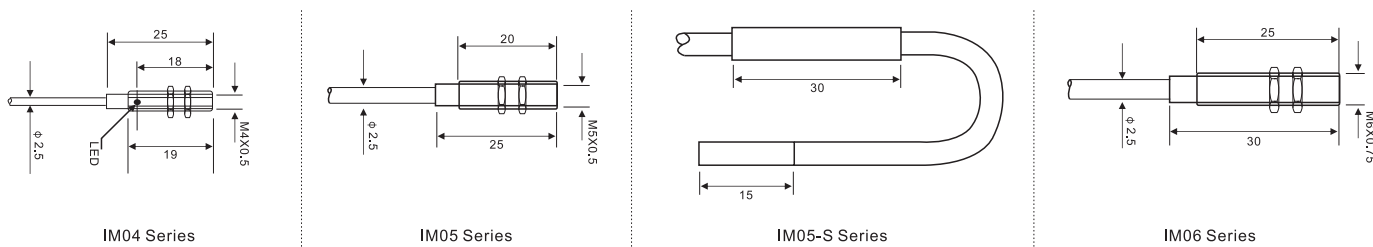

Wiring Diagram

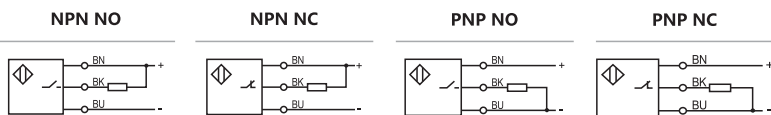



- Features
- Easy for connection, installation and application
- Super long sensing distance
- Stable and reliable
- Flexible cable
- Degree of protection: IP67
- Ambient temperature: -25~+70°C

IMD	04	-	01	NA	F
Series IMD Series	Size 04: M4 05: M5 06: M6		Sensing Distance 01: 1mm 1R5: 1.5mm	Output Mode NA: NPN NO NB: NPN NC PA: PNP NO PB: PNP NC	Shielding F: Shielded

Model				
NPN NO	IMD04-01NAF	IMD05-1R5NAF	IMD05-1R5NAF-S ^③	IMD06-1R5NAF
NPN NC	IMD04-01NBF	IMD05-1R5NBF	IMD05-1R5NBF-S	IMD06-1R5NBF
PNP NO	IMD04-01PAF	IMD05-1R5PAF	IMD05-1R5PAF-S	IMD06-1R5PAF
PNP NC	IMD04-01PBF	IMD05-1R5PBF	IMD05-1R5PBF-S	IMD06-1R5PBF

Specification				
Sensing Distance ^①	1mm	1.5mm	1.5mm	1.5mm
Set Distance	0~0.8mm	0~1.2mm	0~1.2mm	0~1.2mm
Standard Sensing Object	4×4×1mm Ferrous metal	5×5×1mm Ferrous metal	5×5×1mm Ferrous metal	6×6×1mm Ferrous metal
Response Frequency ^②	1KHz			
Response Time	0.3ms			
Differential Travel	15% Max. of sensing distance			
Detectable Object	Ferrous Metal (The sensing distance decreases with non-ferrous metal. Refer to Data sheet)			
Power Supply Voltage (Operating Voltage Range)	12~24VDC, Ripple(p-p) 10% Max. (10~30DC full wave rectifier power supply)			
Current Consumption	10mA Max. @24VDC			
Load Current	Max.100mA		Max.150mA	
Residual Voltage	1.5V Max. @100mA load and 2M cable			
Leakage Current	0.01mA Max. @ 24VDC			
Indicators	Red			
Operation Mode	NA-Model: NO, NB-Model: NC.			
Short Circuit Protection	—		≥180mA	
Protection Circuit	—		Reverse Polarity protection, Surge suppressor	
Ambient Temperature Range	Operating / storage: -25~+70°C (with no icing or condensation)			
Ambient Humidity Range	Operating / storage: 35-95% (with no condensation)			
Temperature Influence	±10% Max. of sensing distance @+25°C in the temperature range			
Insulation Resistance	50MΩ Min. (at 500VDC) between current carrying parts and case			
Dielectric Strength	1000VAC 50/60Hz for 1 minute between current carrying parts and case			
Vibration/Shock Resistance	IEC 60947-5-2, Part7.4.1 / IEC 60947-5-2, Part7.4.2			
EMC	RFI>3V/M / EFT>1KV / ESD>4KV(contact)			
Degree of Protection	IEC standards EN60529:IP67			
Connection Method	Pre-wired 2M			
Weight (Packed state)	~15g	~20g	~20g	~23g
Materials of Case	Stainless Steel			
Materials of Sensing Surface	PA66			
Accessories	Clamping nuts. Mounting bracket available(optional)			

① Sensing distance, range ±10%. ② Response frequency is an average value. Measure condition is as follow: standard sensing object, a setting distance of half the sensing distance. ③ The model of -s is circuit board split type

Dimension Diagram Unit: mm

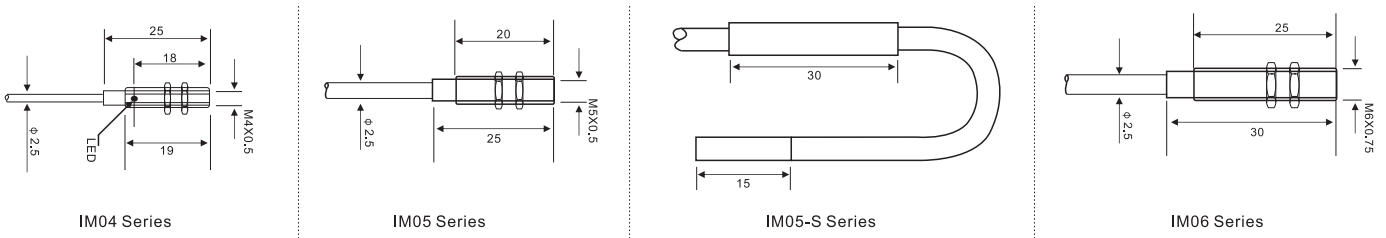

Wiring Diagram





- Features
- Easy for connection, installation and application
- High response frequency
- Stable and reliable
- Flexible cable
- Degree of protection: IP67
- Ambient temperature: -25~+70°C

IS	04	-	R8	NA	F
Series IS Series	Size 03: Φ3 05: Φ4 06: Φ6.5		Sensing Distance R8: 0.8mm 01: 1mm 02: 2mm	Output Mode NA: NPN NO NB: NPN NC PA: PNP NO PB: PNP NC	Shielding F: Shielded N: Unshielded

Model								
NPN NO	IS03-R8NAF	IS03-R8NAF-S ^③	IS04-01NAF	IS04-01NAF-S	IS06-01NAF	IS06-02NAF	IS06-01NAF-S	IS06-02NAF-S
NPN NC	IS03-R8NBF	IS03-R8NBF-S	IS04-01NBF	IS04-01NBF-S	IS06-01NBF	IS06-02NBF	IS06-01NBF-S	IS06-02NBF-S
PNP NO	IS03-R8PAF	IS03-R8PAF-S	IS04-01PAF	IS04-01PAF-S	IS06-01PAF	IS06-02PAF	IS06-01PAF-S	IS06-02PAF-S
PNP NC	IS03-R8PBF	IS03-R8PBF-S	IS04-01PBF	IS04-01PBF-S	IS06-01PBF	IS06-02PBF	IS06-01PBF-S	IS06-02PBF-S

Specification								
Sensing Distance ^①	0.8mm		1mm		1mm	2mm	1mm	2mm
Set Distance	0~0.64mm		0~0.8mm		0~0.8mm	0~1.6mm	0~0.8mm	0~1.6mm
Standard Sensing Object	3×3×1mm Ferrous metal		4×4×1mm Ferrous metal		6.5×6.5×1mm Ferrous metal	12×12×1mm Ferrous metal	6.5×6.5×1mm Ferrous metal	12×12×1mm Ferrous metal
Response Frequency ^②	1KHz							
Response Time	0.3ms							
Differential Travel	15% Max. of sensing distance							
Detectable Object	Ferrous Metal (The sensing distance decreases with non-ferrous metal. Refer to Data sheet)							
Power Supply Voltage (Operating Voltage Range)	12~24VDC, Ripple(p-p) 10% Max. (10~30DC full wave rectifier power supply)							
Current Consumption	10mA Max. @240VDC							
Load Current	Max.100mA				Max.150mA			
Residual Voltage	1.5V Max. @100mA load and 2M cable							
Leakage Current	0.01mA Max. @ 24VDC							
Indicators	Red							
Operation Mode	NA-Model: NO, NB-Model: NC.							
Short Circuit Protection	—				≥180mA			
Protection Circuit	—				Reverse Polarity protection, Surge suppressor			
Ambient Temperature Range	Operating / storage: -25~+70°C (with no icing or condensation)							
Ambient Humidity Range	Operating / storage: 35-95% (with no condensation)							
Temperature Influence	±10% Max. of sensing distance @+25°C in the temperature range							
Insulation Resistance	50MΩ Min. (at 500VDC) between current carrying parts and case							
Dielectric Strength	1000VAC 50/60Hz for 1 minute between current carrying parts and case							
Vibration/Shock Resistance	IEC 60947-5-2, Part7.4.1 / IEC 60947-5-2, Part7.4.2							
EMC	RFI>3V/M / EFT>1KV / ESD>4KV(contact)							
Degree of Protection	IEC standards EN60529:IP67							
Connection Method	Pre-wired 2M							
Weight (Packed state)	~15g	~15g	~20g	~20g	~20g	~20g	~23g	~23g
Materials of Case	Stainless Steel							
Materials of Sensing Surface	PA66				PBT			
Accessories	—							

① Sensing distance, range ±10%. ② Response frequency is an average value. Measure condition is as follow: standard sensing object, a setting distance of half the sensing distance. ③ -s for the short circuit board separation shape

Dimension Diagram Unit: mm

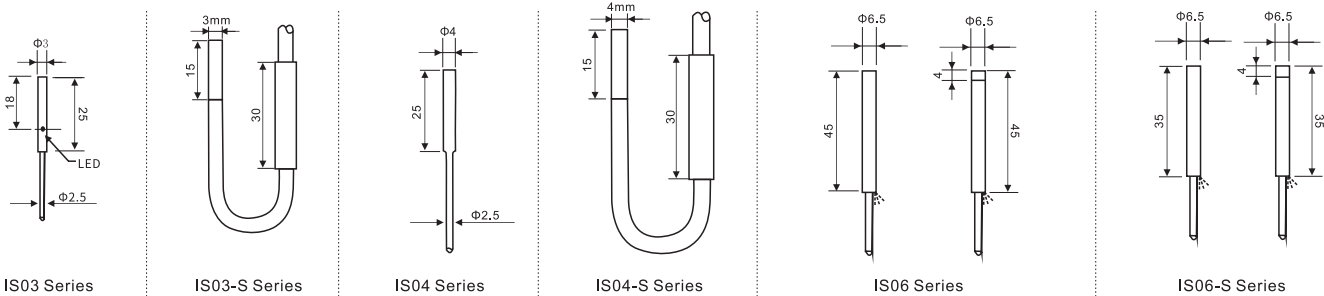

Wiring Diagram

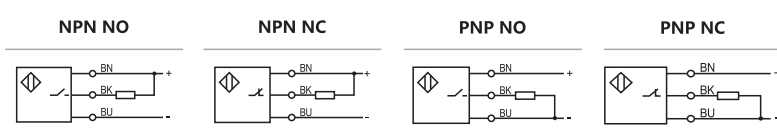



- Features
- Easy for connection, installation and application
- Super long sensing distance
- Stable and reliable
- Flexible cable
- Degree of protection: IP67
- Ambient temperature: -25~+70°C

ISD	06	-	04	NA	N
Series ISD Series	Size 03: Φ3 05: Φ4 06: Φ6.5		Sensing Distance 01: 1mm 1R5: 1.5mm 02: 2mm 03: 3mm 04: 4mm	Output Mode NA: NPN NO NB: NPN NC PA: PNP NO PB: PNP NC	Shielding F: Shielded N: Unshielded

Model	ISD03-01NAF		ISD03-01NAF-S ^③		ISD04-1R5NAF		ISD04-1R5NAF-S		ISD06-02NAF		ISD06-03NAF		ISD06-04NAN		ISD06-06NAN	
NPN NO	ISD03-01NAF	ISD03-01NAF-S ^③	ISD04-1R5NAF	ISD04-1R5NAF-S	ISD06-02NAF	ISD06-03NAF	ISD06-04NAN	ISD06-06NAN								
NPN NC	ISD03-01NBF	ISD03-01NBF-S	ISD04-1R5NBF	ISD04-1R5NBF-S	ISD06-02NBF	ISD06-03NBF	ISD06-04NBN	ISD06-06NBN								
PNP NO	ISD03-01PAF	ISD03-01PAF-S	ISD04-1R5PAF	ISD04-1R5PAF-S	ISD06-02PAF	ISD06-03PAF	ISD06-04PAN	ISD06-06PAN								
PNP NC	ISD03-01PBF	ISD03-01PBF-S	ISD04-1R5PBF	ISD04-1R5PBF-S	ISD06-02PBF	ISD06-03PBF	ISD06-04PBN	ISD06-06PBN								

Specification	
Sensing Distance ^①	1mm 1.5mm 2mm 3mm 4mm 6mm
Set Distance	0~0.8mm 0~1.2mm 0~1.6mm 0~2.4mm 0~3.2mm 0~4.8mm
Standard Sensing Object	3×3×1mm Ferrous metal 4×4×1mm Ferrous metal 6.5×6.5×1mm Ferrous metal 12×12×1mm Ferrous metal 6.5×6.5×1mm Ferrous metal 12×12×1mm Ferrous metal
Response Frequency ^②	1KHz 1KHz 1KHz 500Hz 800Hz 400Hz
Response Time	0.3ms 0.3ms 0.1ms 0.5ms 0.2ms 1ms
Differential Travel	15% Max. of sensing distance
Detectable Object	Ferrous Metal (The sensing distance decreases with non-ferrous metal. Refer to Data sheet)
Power Supply Voltage (Operating Voltage Range)	12~24VDC, Ripple(p-p) 10% Max. (10~30DC full wave rectifier power supply)
Current Consumption	10mA Max. @24VDC
Load Current	Max.100mA Max.150mA
Residual Voltage	1.5V Max. @100mA load and 2M cable
Leakage Current	0.01mA Max. @ 24VDC
Indicators	Red
Operation Mode	NA-Model: NO, NB-Model: NC.
Short Circuit Protection	— ≥180mA
Protection Circuit	— Reverse Polarity protection, Surge suppressor
Ambient Temperature Range	Operating / storage: -25~+70°C (with no icing or condensation)
Ambient Humidity Range	Operating / storage: 35-95% (with no condensation)
Temperature Influence	±10% Max. of sensing distance @+25°C in the temperature range
Insulation Resistance	50MΩ Min. (at 500VDC) between current carrying parts and case
Dielectric Strength	1000VAC 50/60Hz for 1 minute between current carrying parts and case
Vibration/Shock Resistance	IEC 60947-5-2, Part7.4.1 / IEC 60947-55-2, Part7.4.2
EMC	RFI>3V/M / EFT>1KV / ESD>4KV(contact)
Degree of Protection	IEC standards EN60529:IP67
Connection Method	Pre-wired 2M
Weight (Packed state)	~15g ~15g ~20g ~20g ~20g ~20g ~23g ~23g
Materials of Case	Stainless Steel
Materials of Sensing Surface	PA66 PBT
Accessories	—

① Sensing distance, range ±10%. ② Response frequency is an average value. Measure condition is as follow: standard sensing object, a setting distance of half the sensing distance. ③ -s for the short circuit board separation shape

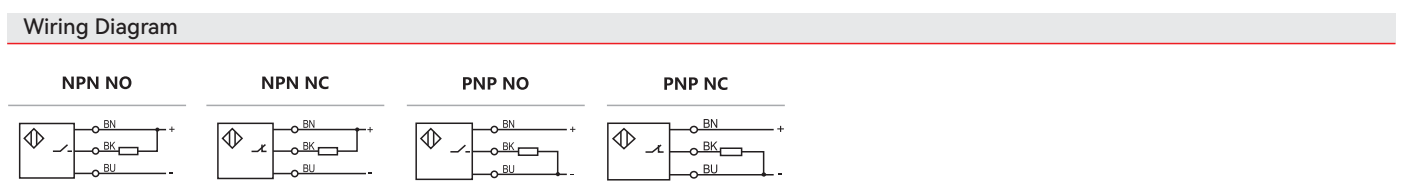
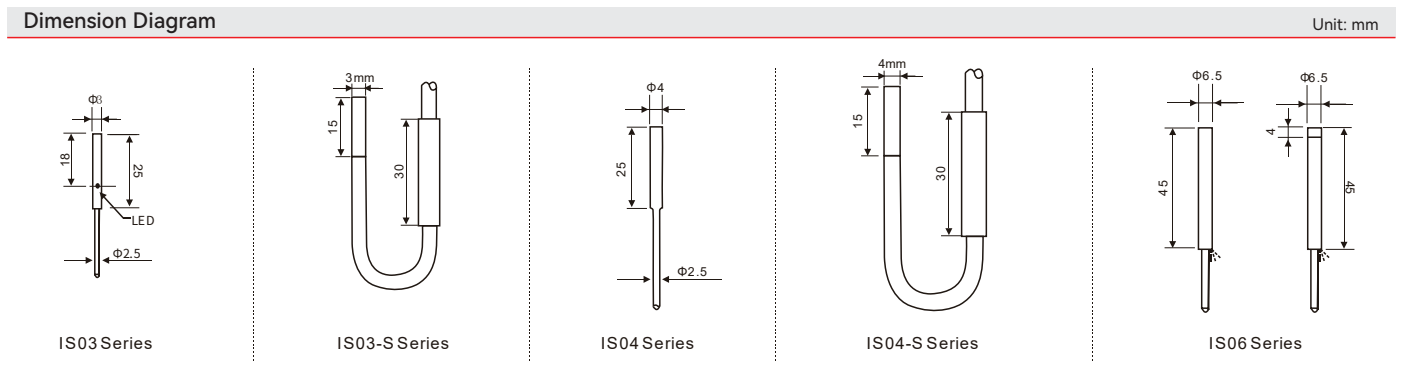



- Features
 - Easy for connection, installation and application
 - Super long sensing distance
 - Stable and reliable
 - Flexible cable
 - Degree of protection: IP67
 - Ambient temperature: -25~+70°C

ISV2	06	A	-	01	NA	F
Series IYV3 Series	Size 06: Φ6.5	Connector Size A: M8 Connector Size		Sensing Distance 01: 1mm 02: 2mm	Output Mode NA: NPN NO NB: NPN NC PA: PNP NO PB: PNP NC	Shielding F: Shielded N: Unshielded

Model								
NPN NO	ISV206A-01NAF ^①	ISV206A-02NAF	ISV306A-01NAF ^②	ISV306A-02NAN	ISV506A-02NAF ^③	ISV506A-03NAF	ISV506A-04NAN	ISV506A-06NAN
NPN NC	ISV206A-01NBF	ISV206A-02NBF	ISV306A-01NBF	ISV306A-02NBN	ISV506A-02NBF	ISV506A-03NBF	ISV506A-04NBN	ISV506A-06NBN
PNP NO	ISV206A-01PAF	ISV206A-02PAF	ISV306A-01PAF	ISV306A-02PAN	ISV506A-02PAF	ISV506A-03PAF	ISV506A-04PAN	ISV506A-06PAN
PNP NC	ISV206A-01PBF	ISV206A-02PBF	ISV306A-01PBF	ISV306A-02PBN	ISV506A-02PBF	ISV506A-03PBF	ISV506A-04PBN	ISV506A-06PBN
Connecting Line	P02-F083A2/P02-F083S2			P02-F124A2/P02-F124S2				

Specification								
Sensing Distance ^①	1mm	2mm	1mm	2mm	1mm	3mm	4mm	6mm
Set Distance	0~0.8mm	0~1.6mm	0~0.8mm	0~1.6mm	0~0.8mm	0~2.4mm	0~3.2mm	0~4.8mm
Standard Sensing Object	6.5×6.5×1mm Ferrous metal	12×12×1mm Ferrous metal	6.5×6.5×1mm Ferrous metal	12×12×1mm Ferrous metal	6.5×6.5×1mm Ferrous metal	6.5×6.5×1mm Ferrous metal	12×12×1mm Ferrous metal	12×12×1mm Ferrous metal
Response Frequency ^②	2KHz	2KHz	2KHz	2KHz	1KHz	500Hz	800Hz	400Hz
Response Time	0.1ms	0.1ms	0.1ms	0.1ms	0.1ms	0.5ms	0.2ms	1ms
Differential Travel	15% Max. of sensing distance							
Detectable Object	Ferrous Metal (The sensing distance decreases with non-ferrous metal. Refer to Data sheet)							
Power Supply Voltage (Operating Voltage Range)	12~24VDC, Ripple(p-p) 10% Max. (10~30DC full wave rectifier power supply)							
Current Consumption	10mA Max. @24VDC							
Load Current	Max.150mA							
Residual Voltage	1.5V Max. @100mA load and 2M cable							
Leakage Current	0.01mA Max. @ 24VDC							
Indicators	Red							
Operation Mode	NA-Model: NO, NB-Model: NC.							
Short Circuit Protection	≥180mA							
Protection Circuit	Reverse Polarity protection, Surge suppressor							
Ambient Temperature Range	Operating / storage: -25~+70°C (with no icing or condensation)							
Ambient Humidity Range	Operating / storage: 35-95% (with no condensation)							
Temperature Influence	±10% Max. of sensing distance @+25°C in the temperature range							
Insulation Resistance	50MΩ Min. (at 500VDC) between current carrying parts and case							
Dielectric Strength	1000VAC 50/60Hz for 1 minute between current carrying parts and case							
Vibration/Shock Resistance	IEC 60947-5-2, Part7.4.1 / IEC 60947-5-2, Part7.4.2							
EMC	RFI>3V/M / EFT>1KV / ESD>4KV(contact)							
Degree of Protection	IEC standards EN60529:IP67							
Connection Method	Connector (M8 3-pin)							
Weight (Packed state)	~8g	~8g	~10g	~10g	~13g	~13g	~14g	~14g
Materials of Case	Stainless Steel							
Materials of Sensing Surface	PBT							
Accessories	—							

① Sensing distance, range ±10%. ② Response frequency is an average value. Measure condition is as follow: standard sensing object, a setting distance of half the sensing distance.
 ③ ISV2 Series I/O Short Small Diameter Cylindrical Proximity Switch. ④ ISV3 Series I/O General Cylindrical Proximity Switch. ⑤ ISV5 Series I/O Long Distance Cylindrical Proximity Switch.

Dimension Diagram Unit: mm

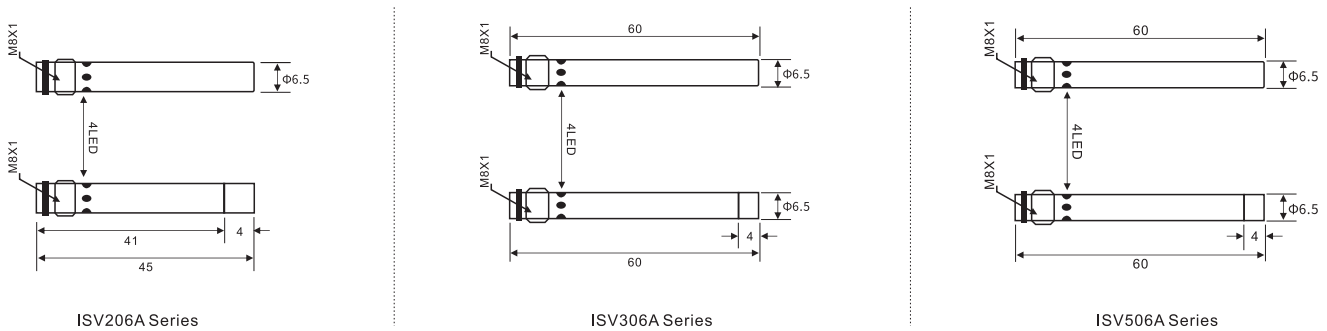

Wiring Diagram





- Features
 - Response frequency: 2KHz
 - Surge suppressor
 - Degree of protection: IP67
 - Ambient temperature: -25~+70°C

IPE	10	-	F	04	NA
Series IPE Series	Size 08: 8×8×25mm 10: 10×10×30mm		Sensing surface F: F-type (TOP) T: T-type (Front)	Sensing Distance 03: 3mm 04: 4mm	Output Mode NA: NPN NO NB: NPN NC PA: PNP NO PB: PNP NC

Model				
NPN NO	IPE08-F02NA	IPE08-T02NA	IPE10-F03NA	IPE10-F04NA
NPN NC	IPE08-F02NB	IPE08-T02NB	IPE10-F03NB	IPE10-F04NB
PNP NO	IPE08-F02PA	IPE08-T02PA	IPE10-F03PA	IPE10-F04PA
PNP NC	IPE08-F02PB	IPE08-T02PB	IPE10-F03PB	IPE10-F04PB

Specification				
Sensing surface	F-type (TOP)	T-type (Front)	F-type (TOP)	
Sensing Distance ①	2.5mm	2.5mm	3mm	4mm
Set Distance	0~2mm	0~2mm	0~2mm	0~3.2mm
Differential Travel	10% Max. of sensing distance			
Detectable Object	Ferrous Metal (The sensing distance decreases with non-ferrous metal. Refer to Data sheet)			
Standard Sensing Object	10×10×1mm ferrous metal			
Response Frequency ②	2000Hz			
Response Time	0.1ms			
Power Supply Voltage (Operating Voltage Range)	10-30VDC, Ripple(p-p) 10% Max. (full wave rectifier power supply)			
Current consumption	10mA Max. @24VDC			
Load Current	150mA Max			
Residual Voltage	0.01mA Max. @ 24VDC			
Leakage Current	Red			
Indicators	NA-Model: NO, NB-Model: NC.			
Operation Mode	≥180mA			
Short Circuit Protection	Overload/Short circuit protection			
Protection Circuit	Reverse Polarity protection, Surge suppressor			
Ambient Temperature Range	Operating / storage: -25~+70°C (with no icing or condensation)			
Ambient Humidity Range	Operating / storage: 35-95% (with no condensation)			
Temperature Influence	±10% Max. of sensing distance @+25°C in the temperature range			
Insulation Resistance	50MΩ Min. (at 500VDC) between current carrying parts and case			
Dielectric Strength	1000VAC 50/60Hz for 1 minute between current carrying parts and case			
Vibration/Shock Resistance	IEC 60947-5-2, Part7.4.1 / IEC 60947-55-2, Part7.4.2		10-55Hz 1.5mm double amplitude for 2 hours each in X,Y,Z directions	
EMC	RFI>3V/M / EFT>1KV / ESD>4KV(contact)		500m/S ² 10 times each in X, Y and Z directions	
Degree of Protection	IEC standards EN60529:IP67			
Connection Method	Pre-wired 2M		IP67(I lead type (standard line length 2 meters) EC standard EN60529)	
Weight (Packed state)	~30g			
Dimensions	8×8×23mm	8×8×27mm	10×6×30mm	10×6.5×30mm
Materials of Case	PC		PBT	
Accessories	Clamping nuts. Mounting bracket available(optional)			

① Sensing distance, range ±10%. ② Response frequency is an average value. Measure condition is as follow: standard sensing object, a setting distance of half the sensing distance.

Dimension Diagram Unit: mm

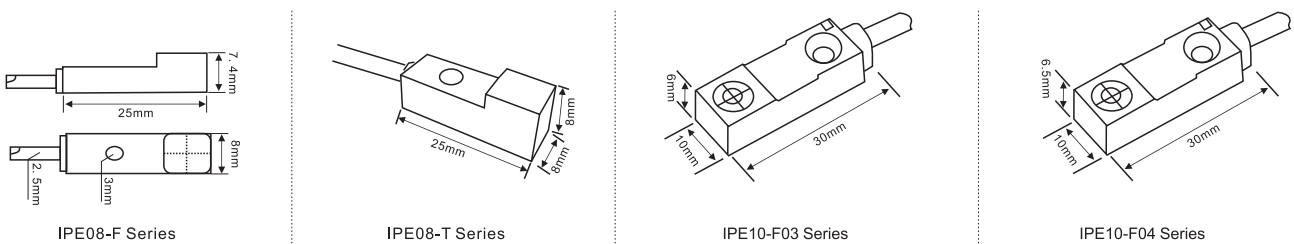

Wiring Diagram





- Features
 - Easy for connection, installation and application
 - Super long sensing distance
 - Flexible cable
 - Degree of protection: IP67
 - Ambient temperature: -25~+70°C

IP2	1	-	05	NA
Series	Size		Sensing Distance	Output Mode
IP2 Series	01: 18×18 (Small square)		05: 5mm	NA: NPN NO
IPK2 Series	02: 25×25 (Middle square)		10: 10mm	NB: NPN NC
IP4 Series	03: 30×30 (Big square)			PA: PNP NO
	04: 18×10 (Square)			PB: PNP NC

Model							
NPN NO	IP21-05NA	IP21-05NAR	IP21-08NA	IP22-10NA	IP23-15NA	IP24-05NA	IP24-08NA
NPN NC	IP21-05NB	IP21-05NBR	IP21-08NB	IP22-10NB	IP23-15NB	IP24-05NB	IP24-08NB
PNP NO	IP21-05PA	IP21-05PAR	IP21-08PA	IP22-10PA	IP23-15PA	—	—
PNP NC	IP21-05PB	IP21-05PBR	IP21-08PB	IP22-10PB	IP23-15PB	—	—

Ordering model (IPK2 Series anti-interference square proximity switch)							
NPN NO	IPK21-05NA	—	IPK21-08NA	IPK22-10NA	IPK23-15NA	—	—
NPN NC	IPK21-05NB	—	IPK21-08NB	IPK22-10NB	IPK23-15NB	—	—
PNP NO	IPK21-05PA	—	IPK21-08PA	IPK22-10PA	IPK23-15PA	—	—
PNP NC	IPK21-05PB	—	IPK21-08PB	IPK22-10PB	IPK23-15PB	—	—

Ordering model (IP41 Series 3 state high-performance square proximity switch)							
NPN NO	IPK41-05NA	—	IP41-08NA	IP42-10NA	IP43-15NA	—	—
NPN NC	IPK41-05NB	—	IP41-08NB	IP42-10NB	IP43-15NB	—	—
PNP NO	IPK41-05PA	—	IP41-08PA	IP42-10PA	IP43-15PA	—	—
PNP NC	IPK41-05PB	—	IP41-08PB	IP42-10PB	IP43-15PB	—	—

Specification							
Sensing Distance	5mm	5mm	8mm	10mm	15mm	5mm	8mm
Set Distance	0~4mm	0~4mm	0~6.4mm	0~8mm	0~12mm	0~4mm	0~6.4mm
Response Frequency	1000Hz	500Hz	500Hz	300Hz	1000Hz	500Hz	600Hz
Detectable Object	Ferrous Metal (The sensing distance decreases with non-ferrous metal. Refer to Data sheet)						
Differential Travel	10% Max. of sensing distance						
Power Supply Voltage (Operating Voltage Range)	12-24VDC, Ripple (p-p) 10% Max. (full wave rectifier power supply 10-30VDC)						
Current consumption	5mA Max. @NPN. 7mA Max. @PNP. 100mA Max. @12VDC. 200mA Max. @24VDC						
Load Current	100mA Max						
Residual Voltage	1.5V Max.						
Indicators	IP2/IPK2: Green—Standby. Red—Operating IP4: Green—Standby. Red—Operating. Flash--Fault						
Operation Mode	NA-Model: NO, NB-Model: NC. PA-Model: PNP NO. PB-Model: PNP NC						
Short Circuit Protection	Overload/Short circuit protection. LED flash in protection state						
Protection Circuit	Reverse Polarity Protection/Surge Suppressor						—
Ambient Temperature Range	Operating / storage: -30~+70°C (with no icing or condensation)						
Ambient Humidity Range	Operating / storage: 35-95% (with no condensation)						-25~+70°C
Temperature Influence	±10% Max. of sensing distance @+25°C in the temperature range						
Voltage Influence	±1% Max. of sensing distance @rated voltage in the rated voltage ±10% range						
Anti-interference	IPK2: Strong Resistance against Magnetic Interference						
Insulation Resistance	50MΩ Min. (at 500VDC) between current carrying parts and case						
Dielectric Strength	1000VAC 50/60Hz for 1 minute between current carrying parts and case						
Vibration Resistance	10-55Hz 1.5mm double amplitude for 2 hours each in X,Y,Z directions						
Shock Resistance	500m/S ² 10 times each in X, Y and Z directions						
Degree of Protection	IEC standards EN60529:IP67. Oil resistance in-house standards						
Connection Method	Pre-wired 2M (other length requirement available)						
Materials of Case	PBT						
Accessories	Clamping nuts. Mounting bracket available (optional)						
Certificate	CE						

① Sensing distance, range ±10%. ② Response frequency is an average value. Measure condition is as follow: standard sensing object, a setting distance of half the sensing distance.
③ Recommended application within the setting distance as to reach the best detect effect.

Dimension Diagram Unit: mm

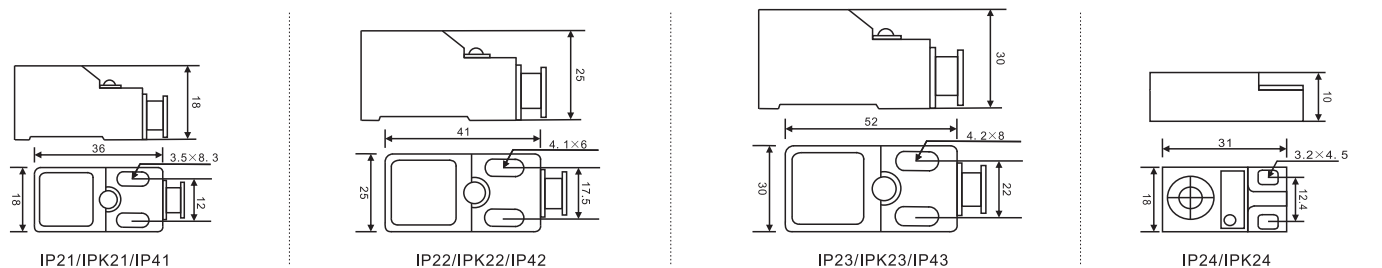

Wiring Diagram





- Features
 - NPN/PNP output identify intelligently. Reduce the confusion of product selection
 - Indicators: Operation state: NPN-Green/PNP-Red. Fault NPN-Red flash/PNP-Green flash
 - NO/NC output model distinguished by different color. Reduce the wiring error
 - Strongly anti-interference design.
 - Suitable for side-by-side installation and magnetic environment application (IPK3 Series)
 - Oil-resistant cable
 - 2M pre-wired cable (other length cable available)

IP3	1	-	05	NA
Series IP3 Series	Size 1: Small square type		Sensing Distance 05: 5mm	Output Mode A: NO B: NC

Model	
NO	IP31-05A
NC	IP31-05B
Specification	
Sensing Distance	5mm
Set Distance	0~4.0mm
Differential Travel	10% Max. of sensing distance
Detectable Object	Ferrous Metal (The sensing distance decreases with non-ferrous metal. Refer to Data sheet)
Response Frequency	1000Hz
Power Supply Voltage (Operating Voltage Range)	12-24VDC, Ripple (p-p) 10% Max. (full wave rectifier power supply 10-30VDC)
Current consumption	5mA Max. @NPN. 7mA Max. @PNP
Load Current	100mA Max
Residual Voltage	1.5V Max.
Indicators	Green — Standby. Red — Operating. Flash--Fault
Operation Mode	A-Model: NPN+PNP NO. B-Model: NPN+ PNP NC
Short Circuit Protection	Overload/Short circuit protection. LED flash in protection state
Protection Circuit	Reverse Polarity Protection/Surge Suppressor
Ambient Temperature Range	Operating / storage: -30~+70°C (with no icing or condensation)
Ambient Humidity Range	Operating / storage: 35-95% (with no condensation)
Temperature Influence	±10% Max. of sensing distance @+25°C in the temperature range
Voltage Influence	±1% Max. of sensing distance @rated voltage in the rated voltage ±10% range
Anti-interference	IPK3: Strong Resistance against Magnetic Interference
Insulation Resistance	50MΩ Min. (at 500VDC) between current carrying parts and case
Dielectric Strength	1000VAC 50/60Hz for 1 minute between current carrying parts and case
Vibration Resistance	10-55Hz 1.5mm double amplitude for 2 hours each in X,Y,Z directions
Shock Resistance	500m/S ² 10 times each in X, Y and Z directions
Degree of Protection	IEC standards:IP67. Oil resistance in-house standards
Connection Method	Pre-wired 2M (other length requirement available)
Materials of Case	PBT
Accessories	Clamping nuts. Mounting bracket available(optional)
Certificate	CE

Dimension Diagram

Unit: mm

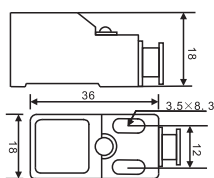

IP31/IPK31

Wiring Diagram

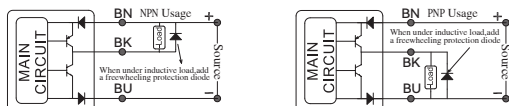



- Features
 - Φ6, Φ8, Φ10, Φ12, Φ15, Φ19, Φ21
 - LED indicator
 - Built-in surge suppressor & short circuit protection
 - Oil resistant cable
 - Degree of protection: IP67

IGA	-	08	NA
Series IGA Series		Sensing Distance 06: 6mm 08: 8mm 10: 10mm	Output Mode NA: NPN NO NB: NPN NC PA: PNP NO PB: PNP NC

Model							
NPN NO	IGA-06NA	IGA-08NA	IGA-10NA	IGA-12NA	IGA-15NA	IGA-19NA	IGA-21NA
NPN NC	IGA-06NB	IGA-08NB	IGA-10NB	IGA-12NB	IGA-15NB	IGA-19NB	IGA-21NB
PNP NO	IGA-06PA	IGA-08PA	IGA-10PA	IGA-12PA	IGA-15PA	IGA-19PA	IGA-21PA
PNP NC	IGA-06PB	IGA-08PB	IGA-10PB	IGA-12PB	IGA-15PB	IGA-19PB	IGA-21PB

Specification							
Sensing Diameter	6mm	8mm	10mm	12mm	15mm	19mm	21mm
Standard Sensing Object	Φ1×2	Φ1.1×2	Φ1.2×2	Φ1.5×3	Φ2×3	Φ2.5×3	Φ3×3
Differential Travel	10% Max. of sensing distance						
Detectable Object	Ferrous Metal (The sensing distance decreases with non-ferrous metal. Refer to Data sheet)						
Response Frequency	4000Hz						
Power Supply Voltage (Operating Voltage Range)	12-24VDC, Ripple (p-p) 10% Max. (full wave rectifier power supply 10-30VDC)						
Current consumption	Max. 8mA						
Load Current	Max.100mA						
Residual Voltage	Max.2V						
Indicators	Red—Operating						
Operation Mode	NA-Model: NO, NB-Model: NC. PA-Model: PNP NO. PB-Model: PNP NC						
Short Circuit Protection	Overload/Short circuit protection. LED flash in protection state						
Protection Circuit	Reverse Polarity Protection/Surge Suppressor						
Ambient Temperature Range	Operating / storage: -30~+70°C (with no icing or condensation)						
Ambient Humidity Range	Operating / storage: 35-95% (with no condensation)						
Temperature Influence	± 10% Max. of sensing distance @+25°C in the temperature range						
Voltage Influence	± 1% Max. of sensing distance @rated voltage in the rated voltage ± 10% range						
Insulation Resistance	50MΩ Min. (at 500VDC) between current carrying parts and case						
Dielectric Strength	1000VAC 50/60Hz for 1 minute between current carrying parts and case						
Vibration Resistance	10-55Hz 1.5mm double amplitude for 2 hours each in X,Y,Z directions						
Shock Resistance	500m/S ² 10 times each in X, Y and Z directions						
Degree of Protection	IEC standards EN60529:IP67. Oil resistance in-house standards						
Connection Method	Pre-wired 2M(other length requirement available)						
Materials of Case	PBT						
Accessories	Clamping nuts. Mounting bracket available(optional)						
Certificate	CE						

① Response frequency is an average value.

Dimension Diagram Unit: mm

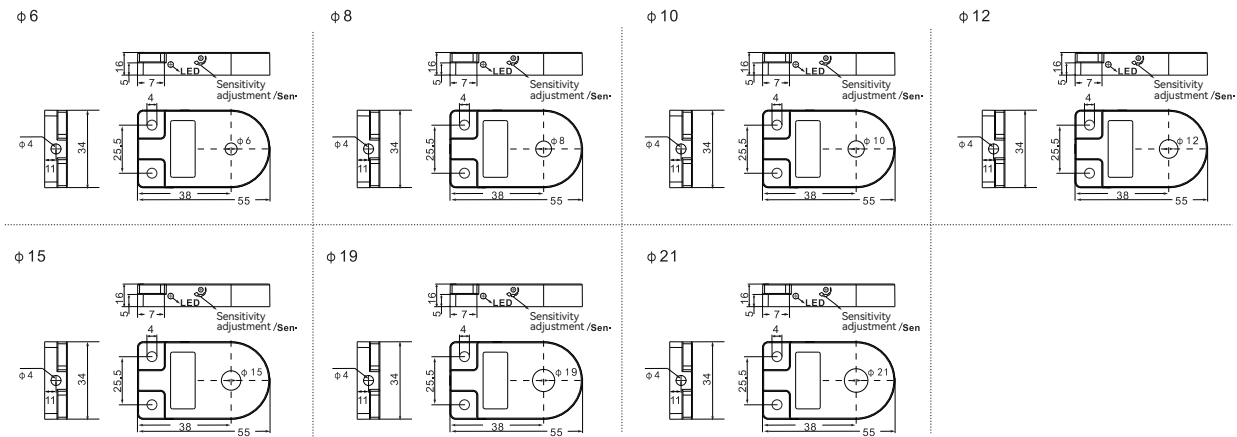

Wiring Diagram

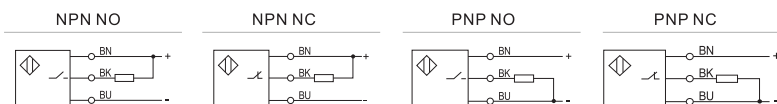



- Features
 - Stable & reliable detection
 - Sensing distance adjustable
 - Protections: Overload/ Short circuit
 - Flexible cable
 - Degree of protection: IP67
 - Ambient temperature: -25~+70°C

IH2	12	-	04	NA	N
Series IH2 Series	Size 12: M12 18: M18 30: M30		Sensing Distance 02: 2mm 04: 4mm 08: 8mm	Output Mode NA: NPN NO NB: NPN NC PA: PNP NO PB: PNP NC	Shielding F: Shielded N: Unshielded

Model						
NPN NO	IH212-02NAF	IH212-04NAN	IH218-05NAF	IH218-08NAN	IH230-10NAF	IH230-15NAN
NPN NC	IH212-02NBF	IH212-04NBN	IH218-05NBF	IH218-08NBN	IH230-10NBF	IH230-15NBN
PNP NO	IH212-02PAF	IH212-04PAN	IH218-05PAF	IH218-08PAN	IH230-10PAF	IH230-15PAN
PNP NC	IH212-02PBF	IH212-04PBN	IH218-05PBF	IH218-08PBN	IH230-10PBF	IH230-15PBN

Specification						
Sensing Distance ①	2mm	4mm	5mm	8mm	10mm	15mm
Adjustment range of Sensing Distance	1~2mm	1~4mm	1~5mm	1~8mm	1~10mm	1~15mm
Standard Sensing Object	Metal plate with earthing 50×50×1mm					
Response Frequency ②	50Hz					
Response Time	1.5ms					
Differential Travel	15% Max. of sensing distance					
Detectable Object	Conductor & Electric medium					
Power Supply Voltage (Operating Voltage Range)	12-24VDC, Ripple (p-p) 10% Max. (full wave rectifier power supply 10-30VDC)					
Current consumption	5mA Max. @NPN. 7mA Max. @PNP					
Load Current	150mA Max					
Residual Voltage	1.5V Max. (@150mA load, 2M cable)					
Leakage Current	0.01mA Max. @24VDC					
Indicators	Red					
Operation Mode	A-Model: NO. B-Model: NC					
Short Circuit Protection	≥180A					
Protection Circuit	Overload/Short circuit protection.					
Ambient Temperature Range	Operating / storage: -25~+70°C (with no icing or condensation)					
Ambient Humidity Range	Operating / storage: 35-95% (with no condensation)					
Temperature Influence	±10% Max. of sensing distance @+25°C in the temperature range					
Insulation Resistance	50MΩ Min. (at 500VDC) between current carrying parts and case					
Dielectric Strength	1000VAC 50/60Hz for 1 minute between current carrying parts and case					
Vibration/Shock Resistance	IEC 60947-5-2, Part 7.4.1 / IEC 60947-5-2, Part 7.4.2					
EMC	RFI>3V/M / EFT>1KV / ESD>4KV(contact)					
Degree of Protection	IEC standards EN60529:IP67					
Connection Method	Pre-wired 2M					
Weight (Packed state)	~70g	~70g	~110g	~120g	~200g	~220g
Materials of Case	ABS					
Materials of Sensing Surface	ABS					
Accessories	Clamping nuts. Mounting bracket available(optional)					

① The data of sensing distance is based on the standard object. Other object please refer to "Relative dielectric constant"
 ② Response frequency is an average of value. The measure condition is as follow: standard object and the setting distance of half sensing distance.

Dimension Diagram

Unit: mm

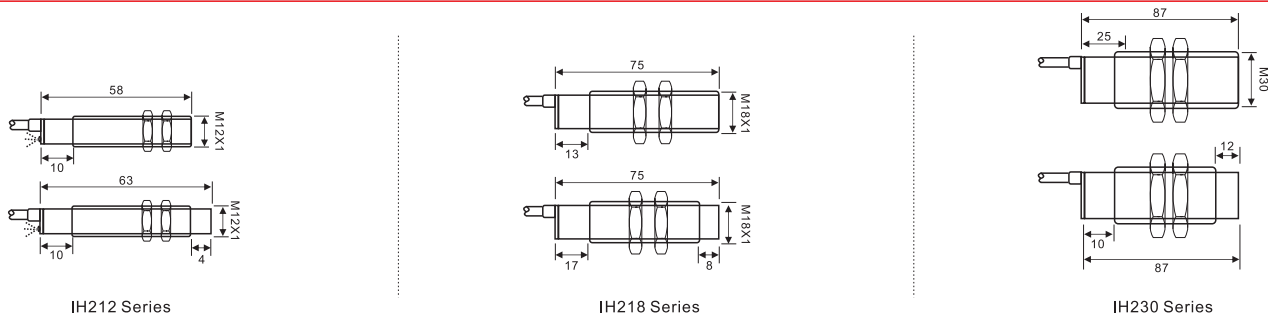

Wiring Diagram

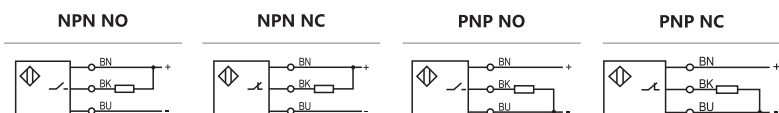



- Features
- Stable & reliable detection
- Sensing distance adjustable
- Protections: Overload/ Short circuit
- Flexible cable
- Degree of protection: IP67
- Ambient temperature: -25~+70°C

IH4	12	-	03	NA	N
Series IH4 Series	Size 12: M12 18: M18 30: M30		Sensing Distance 03: 3mm 06: 6mm 08: 8mm	Output Mode NA: NPN NO NB: NPN NC PA: PNP NO PB: PNP NC	Shielding F: Shielded N: Unshielded

Model						
NPN NO	IH412-03NAF	IH412-06NAN	IH418-08NAF	IH418-15NAN	IH430-20NAF	IH430-30NAN
NPN NC	IH412-03NBF	IH412-06NBN	IH418-08NBF	IH418-15NBN	IH430-20NBF	IH430-30NBN
PNP NO	IH412-03PAF	IH412-06PAN	IH418-08PAF	IH418-15PAN	IH430-20PAF	IH430-30PAN
PNP NC	IH412-03PBF	IH412-06PBN	IH418-08PBF	IH418-15PBN	IH430-20PBF	IH430-30PBN

Specification						
Sensing Distance ①	3mm	6mm	8mm	15mm	20mm	30mm
Adjustment range of Sensing Distance	1~3mm	1~6mm	1~8mm	1~15mm	1~20mm	1~30mm
Standard Sensing Object	Metal plate with earthing 50×50×1mm					
Response Frequency ②	50Hz					
Response Time	1.5ms					
Differential Travel	15% Max. of sensing distance					
Detectable Object	Conductor & Electric medium					
Power Supply Voltage (Operating Voltage Range)	12-24VDC, Ripple (p-p) 10% Max. (full wave rectifier power supply 10-30VDC)					
Current consumption	5mA Max. @NPN. 7mA Max. @PNP					
Load Current	150mA Max					
Residual Voltage	1.5V Max. (@150mA load, 2M cable)					
Leakage Current	0.01mA Max. @24VDC					
Indicators	Red					
Operation Mode	A-Model: NO. B-Model: NC					
Short Circuit Protection	≥180A					
Protection Circuit	Overload/Short circuit protection.					
Ambient Temperature Range	Operating / storage: -25~+70°C (with no icing or condensation)					
Ambient Humidity Range	Operating / storage: 35-95% (with no condensation)					
Temperature Influence	±10% Max. of sensing distance @+25°C in the temperature range					
Insulation Resistance	50MΩ Min. (at 500VDC) between current carrying parts and case					
Dielectric Strength	1000VAC 50/60Hz for 1 minute between current carrying parts and case					
Vibration/Shock Resistance	IEC 60947-5-2, Part 7.4.1 / IEC 60947-5-2, Part 7.4.2					
EMC	RFI>3V/M / EFT>1KV / ESD>4KV(contact)					
Degree of Protection	IEC standards EN60529:IP67					
Connection Method	Pre-wired 2M					
Weight (Packed state)	~70g	~70g	~110g	~120g	~200g	~220g
Materials of Case	ABS					
Materials of Sensing Surface	ABS					
Accessories	Clamping nuts. Mounting bracket available(optional)					

① The data of sensing distance is based on the standard object. Other object please refer to "Relative dielectric constant"
 ② Response frequency is an average of value. The measure condition is as follow: standard object and the setting distance of half sensing distance.

Dimension Diagram Unit: mm

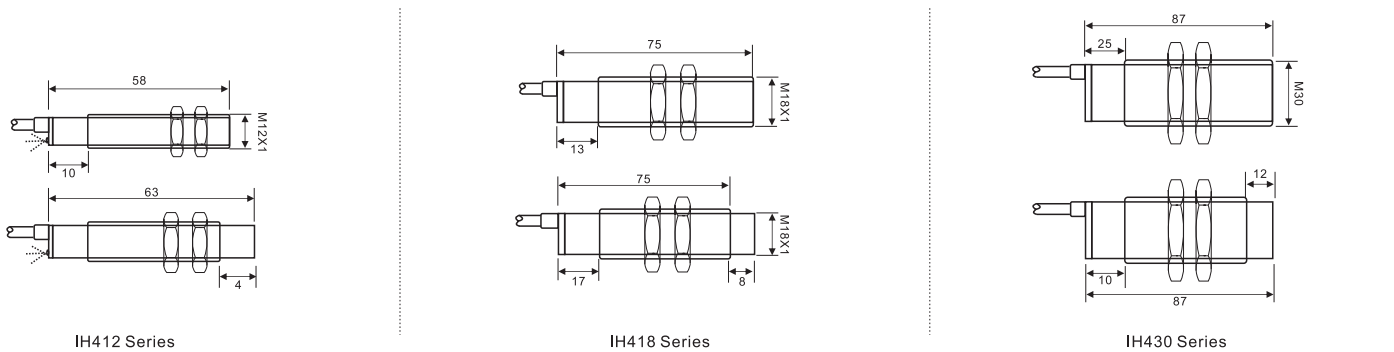

Wiring Diagram





- Features
- Stable & reliable detection
- Sensing distance adjustable
- Protections: Overload/ Short circuit
- Flexible cable
- Degree of protection: IP67
- Ambient temperature: -25~+70°C

IH3	12	-	04	NA	N
Series IH3 Series	Size 12: M12 18: M18 30: M30		Sensing Distance 02: 2mm 04: 4mm 08: 8mm	Output Mode NA: NPN NO NB: NPN NC PA: PNP NO PB: PNP NC	Shielding F: Shielded N: Unshielded

Model	IH308-01NAF	IH308-02NAN	IH312-02NAF	IH312-04NAN	IH318-05NAF	IH318-08NAN
NPN NO	IH308-01NAF	IH308-02NAN	IH312-02NAF	IH312-04NAN	IH318-05NAF	IH318-08NAN
NPN NC	IH308-01NBF	IH308-02NBN	IH312-02NBF	IH312-04NBN	IH318-05NBF	IH318-08NBN
PNP NO	IH308-01PAF	IH308-02PAN	IH312-02PAF	IH312-04PAN	IH318-05PAF	IH318-08PAN
PNP NC	IH308-01PBF	IH308-02PBN	IH312-02PBF	IH312-04PBN	IH318-05PBF	IH318-08PBN

Specification						
Sensing Distance ①	1mm	2mm	2mm	4mm	5mm	8mm
Adjustment range of Sensing Distance	—	—	1~2mm	1~4mm	1~5mm	1~8mm
Standard Sensing Object	Metal plate with earthing 50×50×1mm					
Response Frequency ②	50Hz					
Response Time	1.5ms					
Differential Travel	15% Max. of sensing distance					
Detectable Object	Conductor & Electric medium					
Power Supply Voltage (Operating Voltage Range)	12-24VDC, Ripple (p-p) 10% Max. (full wave rectifier power supply 10-30VDC)					
Current consumption	5mA Max. @NPN. 7mA Max. @PNP					
Load Current	150mA Max					
Residual Voltage	1.5V Max. (@150mA load, 2M cable)					
Leakage Current	0.01mA Max. @24VDC					
Indicators	Red					
Operation Mode	A-Model: NO. B-Model: NC					
Short Circuit Protection	≥180A					
Protection Circuit	Overload/Short circuit protection.					
Ambient Temperature Range	Operating / storage: -25~+70°C (with no icing or condensation)					
Ambient Humidity Range	Operating / storage: 35-95% (with no condensation)					
Temperature Influence	±10% Max. of sensing distance @+25°C in the temperature range					
Insulation Resistance	50MΩ Min. (at 500VDC) between current carrying parts and case					
Dielectric Strength	1000VAC 50/60Hz for 1 minute between current carrying parts and case					
Vibration/Shock Resistance	IEC 60947-5-2, Part 7.4.1 / IEC 60947-5-2, Part 7.4.2					
EMC	RFI>3V/M / EFT>1KV / ESD>4KV(contact)					
Degree of Protection	IEC standards EN60529:IP67					
Connection Method	Pre-wired 2M					
Weight (Packed state)	~50g	~50g	~70g	~70g	~110g	~120g
Materials of Case	Nickel-plated Brass					
Materials of Sensing Surface	PBT					
Accessories	Clamping nuts. Mounting bracket available(optional)					

① The data of sensing distance is based on the standard object. Other object please refer to "Relative dielectric constant"
 ② Response frequency is an average of value. The measure condition is as follow: standard object and the setting distance of half sensing distance.

Dimension Diagram Unit: mm

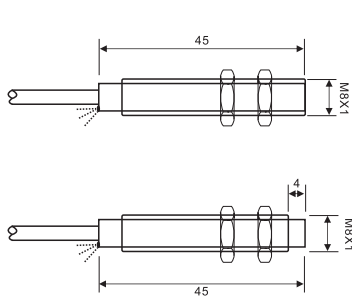

IH308 Series

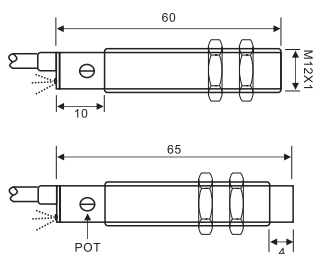

IH312 Series

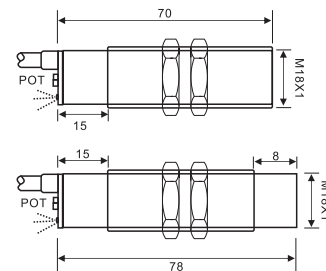

IH318 Series

Wiring Diagram





- Features
- Stable & reliable detection
- Sensing distance adjustable
- Protections: Overload/ Short circuit
- Flexible cable
- Degree of protection: IP67
- Ambient temperature: -25~+70°C

IH5	12	-	04	NA	N
Series IH5 Series	Size 12: M12 18: M18		Sensing Distance 03: 3mm 06: 6mm 08: 8mm	Output Mode NA: NPN NO NB: NPN NC PA: PNP NO PB: PNP NC	Shielding F: Shielded N: Unshielded

Model				
NPN NO	IH512-03NAF	IH512-06NAN	IH518-08NAF	IH518-15NAN
NPN NC	IH512-03NBF	IH512-06NBN	IH518-08NBF	IH518-15NBN
PNP NO	IH512-03PAF	IH512-06PAN	IH518-08PAF	IH518-15PAN
PNP NC	IH512-03PBF	IH512-06PBN	IH518-08PBF	IH518-15PBN

Specification				
Sensing Distance ①	3mm	6mm	8mm	15mm
Adjustment range of Sensing Distance	1~3mm	1~6mm	1~8mm	1~15mm
Standard Sensing Object	Metal plate with earthing 50×50×1mm			
Response Frequency ②	50Hz			
Response Time	1.5ms			
Differential Travel	15% Max. of sensing distance			
Detectable Object	Conductor & Electric medium			
Power Supply Voltage (Operating Voltage Range)	12-24VDC, Ripple (p-p) 10% Max. (full wave rectifier power supply 10-30VDC)			
Current consumption	5mA Max. @NPN. 7mA Max. @PNP			
Load Current	150mA Max			
Residual Voltage	1.5V Max. (@150mA load, 2M cable)			
Leakage Current	0.01mA Max. @24VDC			
Indicators	Red			
Operation Mode	A-Model: NO. B-Model: NC			
Short Circuit Protection	≥180A			
Protection Circuit	Overload/Short circuit protection.			
Ambient Temperature Range	Operating / storage: -25~+70°C (with no icing or condensation)			
Ambient Humidity Range	Operating / storage: 35-95% (with no condensation)			
Temperature Influence	±10% Max. of sensing distance @+25°C in the temperature range			
Insulation Resistance	50MΩ Min. (at 500VDC) between current carrying parts and case			
Dielectric Strength	1000VAC 50/60Hz for 1 minute between current carrying parts and case			
Vibration/Shock Resistance	IEC 60947-5-2, Part 7.4.1 / IEC 60947-5-2, Part 7.4.2			
EMC	RFI>3V/M / EFT>1KV / ESD>4KV(contact)			
Degree of Protection	IEC standards EN60529:IP67			
Connection Method	Pre-wired 2M			
Weight (Packed state)	~70g	~70g	~110g	~120g
Materials of Case	Nickel-plated Brass			
Materials of Sensing Surface	PBT			
Accessories	Clamping nuts. Mounting bracket available(optional)			

① The data of sensing distance is based on the standard object. Other object please refer to "Relative dielectric constant"
 ② Response frequency is an average of value. The measure condition is as follow: standard object and the setting distance of half sensing distance.

Dimension Diagram Unit: mm

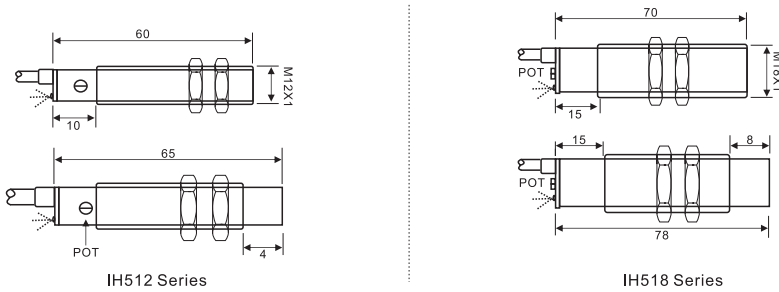

Wiring Diagram

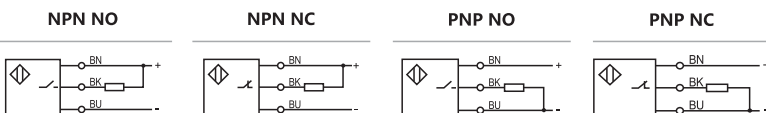



- Features
 - Easy for connection, installation and application
 - Stable & reliable detection
 - Protections: Overload/ Short circuit
 - Flexible cable
 - Degree of protection: IP67
 - Ambient temperature: -25~+70°C

IHV3	12	-	B	04	NA	N
Series IH3 Series	Size 08: M8 12: M12 18: M18		Connector Size A: M8 B: M12	Sensing Distance 03: 3mm 06: 6mm 08: 8mm	Output Mode NA: NPN NO NB: NPN NC PA: PNP NO PB: PNP NC	Shielding F: Shielded N: Unshielded

Model				
NPN NO	IHV312B-02NAF	IHV312B-04NAN	IHV318B-02NAF	IHV318B-08NAN
NPN NC	IHV312B-02NBF	IHV312B-04NBN	IHV312B-02NBF	IHV312B-08NBN
PNP NO	IHV312B-02PAF	IHV312B-04PAN	IHV312B-02PAF	IHV312B-08PAN
PNP NC	IHV312B-02PBF	IHV312B-04PBN	IHV312B-02PBF	IHV312B-08PBN

Specification								
Sensing Distance ①	1mm	2mm	1mm	2mm	2mm	4mm	5mm	8mm
Adjustment range of Sensing Distance	—	—	—	—	0~2mm	0~4mm	0~5mm	0~8mm
Standard Sensing Object	Metal plate with earthing 50×50×1mm							
Response Frequency ②	50Hz							
Response Time	1.5ms							
Differential Travel	15% Max. of sensing distance							
Detectable Object	Conductor & Electric medium							
Power Supply Voltage (Operating Voltage Range)	12-24VDC, Ripple (p-p) 10% Max. (full wave rectifier power supply 10-30VDC)							
Current consumption	5mA Max. @NPN. 7mA Max. @PNP							
Load Current	150mA Max							
Residual Voltage	1.5V Max. (@150mA load, 2M cable)							
Leakage Current	0.01mA Max. @24VDC							
Indicators	Red							
Operation Mode	A-Model: NO. B-Model: NC							
Short Circuit Protection	≥180A							
Protection Circuit	Overload/Short circuit protection.							
Ambient Temperature Range	Operating / storage: -25~+70°C (with no icing or condensation)							
Ambient Humidity Range	Operating / storage: 35-95% (with no condensation)							
Temperature Influence	±10% Max. of sensing distance @+25°C in the temperature range							
Insulation Resistance	50MΩ Min. (at 500VDC) between current carrying parts and case							
Dielectric Strength	1000VAC 50/60Hz for 1 minute between current carrying parts and case							
Vibration/Shock Resistance	IEC 60947-5-2, Part 7.4.1 / IEC 60947-5-2, Part 7.4.2							
EMC	RFI>3V/M / EFT>1KV / ESD>4KV(contact)							
Degree of Protection	IEC standards EN60529:IP67							
Connection Method	Connector: M12, 4pin. IHV3 Series: M8, 3pin							
Weight (Packed state)	~28g	~30g	~28g	~30g	~45g	~50g	~70g	~80g
Materials of Case	Nickel-plated Brass							
Materials of Sensing Surface	PBT							
Accessories	—(Cable is sold separately)							

① The data or sensing distance is based on the standard object. Other object please refer to "Relative dielectric constant"
 ② Response frequency is an average of value. The measure condition is as follow: standard object and the setting distance of half sensing distance.

Dimension Diagram Unit: mm

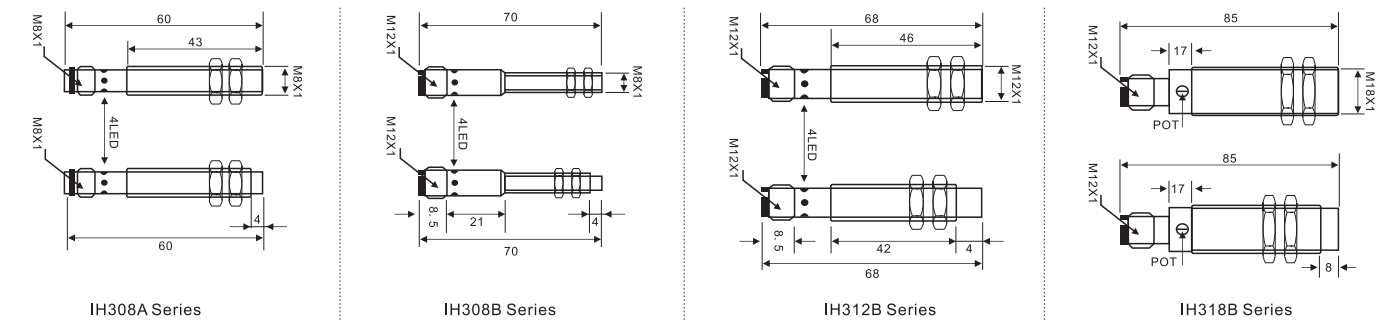

Wiring Diagram

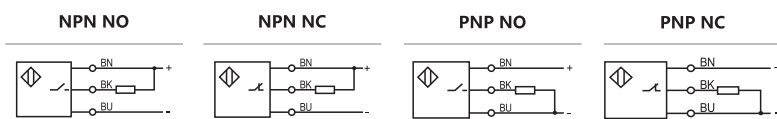



- Features
- Easy for connection, installation and application
- Stable & reliable detection
- Protections: Overload/ Short circuit
- Flexible cable
- Degree of protection: IP67
- Ambient temperature: -25~+70°C

IHV5	12	-	B	06	NA	N
Series IH3 Series	Size 12: M12 18: M18		Connector Size B: M12	Sensing Distance 03: 3mm 06: 6mm 08: 8mm	Output Mode NA: NPN NO NB: NPN NC PA: PNP NO PB: PNP NC	Shielding F: Shielded N: Unshielded

Model				
NPN NO	IHV512B-03NAF	IHV512B-06NAN	IHV518B-08NAF	IHV518B-15NAN
NPN NC	IHV512B-03NBF	IHV512B-06NBN	IHV518B-08NBF	IHV518B-15NBN
PNP NO	IHV512B-03PAF	IHV512B-06PAN	IHV518B-08PAF	IHV518B-15PAN
PNP NC	IHV512B-03PBF	IHV512B-06PBN	IHV518B-08PBF	IHV518B-15PBN

Specification				
Sensing Distance ①	3mm	6mm	8mm	15mm
Adjustment range of Sensing Distance	1~3mm	1~6mm	1~8mm	1~15mm
Standard Sensing Object	Metal plate with earthing 50×50×1mm			
Response Frequency ②	50Hz			
Response Time	1.5ms			
Differential Travel	15% Max. of sensing distance			
Detectable Object	Conductor & Electric medium			
Power Supply Voltage (Operating Voltage Range)	12-24VDC, Ripple (p-p) 10% Max. (full wave rectifier power supply 10-30VDC)			
Current consumption	5mA Max. @NPN. 7mA Max. @PNP			
Load Current	150mA Max			
Residual Voltage	1.5V Max. (@150mA load, 2M cable)			
Leakage Current	0.01mA Max. @24VDC			
Indicators	Red			
Operation Mode	A-Model: NO. B-Model: NC			
Short Circuit Protection	≥180A			
Protection Circuit	Overload/Short circuit protection.			
Ambient Temperature Range	Operating / storage: -25~+70°C (with no icing or condensation)			
Ambient Humidity Range	Operating / storage: 35-95% (with no condensation)			
Temperature Influence	±10% Max. of sensing distance @+25°C in the temperature range			
Insulation Resistance	50MΩ Min. (at 500VDC) between current carrying parts and case			
Dielectric Strength	1000VAC 50/60Hz for 1 minute between current carrying parts and case			
Vibration/Shock Resistance	IEC 60947-5-2, Part 7.4.1 / IEC 60947-5-2, Part 7.4.2			
EMC	RFI>3V/M / EFT>1KV / ESD>4KV(contact)			
Degree of Protection	IEC standards EN60529:IP67			
Connection Method	Connector: M12, 4pin.			
Weight (Packed state)	~45g	~50g	~70g	~80g
Materials of Case	Nickel-plated Brass			
Materials of Sensing Surface	PBT			
Accessories	Clamping nuts. Mounting bracket available(optional)			

① The data or sensing distance is based on the standard object. Other object please refer to "Relative dielectric constant"
 ② Response frequency is an average of value. The measure condition is as follow: standard object and the setting distance of half sensing distance.

Dimension Diagram Unit: mm

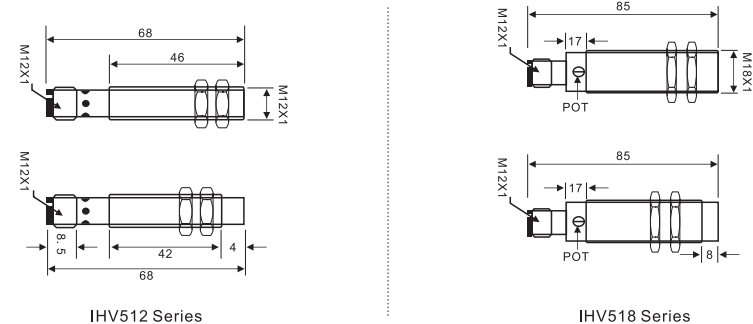

Wiring Diagram

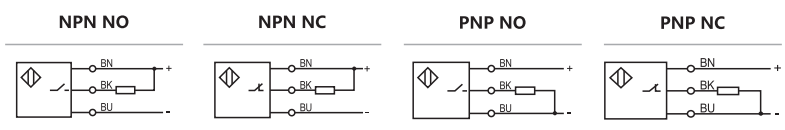



Feature

- Ultra compact size, especially for the small object detection and small space installation
- Bright indicator for conformation from all directions
- High response frequency 3000Hz Max.
- Polarity, Surge and short circuit protection
- Various shapes meet customer's various application
- Soft cable resistant to twists and turns

PW25	-	L	NA	05
Series PW25 Series	Type K L F R	Output Mode N: NPN	Length of power cord 03: 3M 05: 5M	

Type

2M Pre-Wired Models	NPN	PW25-KN	PW25-LN	PW25-FN	PW25-RN	PW25-UN
	PNP	PW25-KP	PW25-LP	PW25-FP	PW25-RP	PW25-UP
5M Pre-Wired Models	NPN	PW25-KN05	PW25-LN05	PW25-FN05	PW25-RN05	PW25-UN05
	PNP	PW25-KP05	PW25-LP05	PW25-FP05	PW25-RP05	PW25-UP05

Specifications

Sensing Distance	5mm (Slot width)
Standard Sensing Object	0.8mm×1.2mm Min. (Opaque)
Differential Distance	0.05mm Max.
Power Supply Voltage	5V~24V DC±10 % Ripple P-P10 % Max.
Light Source/Wave Length	Infrared LED (Wave length: 855nm、Non-modulated)
Operating State Indicator	Red LED
Current Consumption	15mA Max.
Output Control	<NPN Output Models> • Load current: 50mA Max. • Load power supply voltage: 30V DC Max. (Between the output and 0V) • Residual voltage: 2V Max. (When load current is 50mA), 1V Max.(When load current is 16mA)
	<PNP Output Models> • Load current: 50mA Max. • Load power supply voltage: 30V DC Max. (Between the output and +V) • Residual voltage: 2V Max. (When load current is 50mA), 1V Max. (When load current is 16mA)
Output Mode	Light-ON / Dark-ON 2 outputs
Protect Circuit	Polarity protection. Surge suppressor. Load short-circuit protection
Response Frequency/Time	3KHz Max. / Light-ON: 20μsMax., Dark-ON: 80μs Max.
Ambient Illumination	1,000 lx max. with fluorescent light on the surface of the receiver
Ambient Temperature Range	Operating: -25℃~+55℃、Storage: -30℃~+80℃ (With no icing or condensation)
Ambient Humidity Range	Operating: 5%~85%RH,Storage: 5%~95%RH (With no icing or condensation)
Vibration Resistance	10Hz~2000Hz (Peak acceleration 196m/s ²) 1.5mm double amplitude for 2 hours each in XYZ direction
Shock Resistance	15,000m/s ² (About 1,500G) for 3 times each in XYZ direction
Protection class	IP64 (IEC)
Materials	Case: Polybutylene terephthalate (PBT), Emitter/Receiver: Polycarbonate (PC)

Dimension Diagram

Unit: mm

K-type

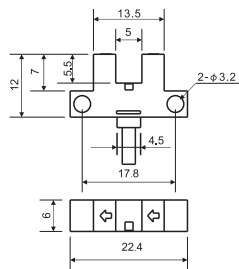

L-shaped

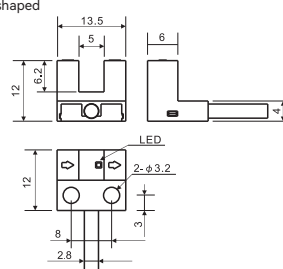

F-type

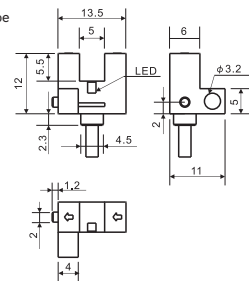

R-type

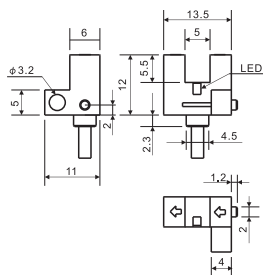

U-shaped

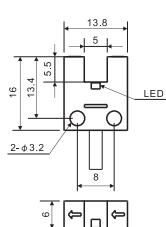

Wiring Diagram

NPN LO+DO

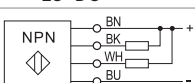

PNP LO+DO

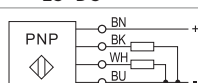



- Feature
 - Bright indicator for conformation from all directions
 - High response frequency 3000Hz Max.
 - Polarity, Surge and short circuit protection
 - Various shapes meet customer's various application
 - Soft cable resistant to twists and turns

PW45	-	L	NA	05
Series PW45 Series		Type K L F R	Output Mode N:NPN	Length of power cord 03:3M 05:5M

Type

2M Pre-Wired Models	NPN	PW45-KN	PW45-LN	PW45-TN	PW45-YN	PW45-FN	PW45-RN
	PNP	PW45-KP	PW45-LP	PW45-TP	PW45-YP	PW45-FP	PW45-RP
5M Pre-Wired Models	NPN	PW45-KN05	PW45-LN05	PW45-TN05	PW45-YN05	PW45-FN05	PW45-RN05
	PNP	PW45-KP05	PW45-LP05	PW45-TP05	PW45-YP05	PW45-FP05	PW45-RP05

Specifications

Sensing Distance	5mm (Slot width)
Standard Sensing Object	0.8mm×1.2mm Min. (Opaque)
Differential Distance	0.05mm Max.
Power Supply Voltage	5V~24V DC±10 % Ripple P-P10 % Max.
Light Source/Wave Length	Infrared LED (Wave length: 855nm. Non-modulated)
Operating State Indicator	Red LED
Current Consumption	15mA Max.
Output Control	<NPN Output Models> <ul style="list-style-type: none"> • Load current: 50mA Max. • Load power supply voltage: 30V DC Max. (Between the output and 0V) • Residual voltage: 2V Max. (When load current is 50mA), 1V Max. (When load current is 16mA)
	<PNP Output Models> <ul style="list-style-type: none"> • Load current: 50mA Max. • Load power supply voltage: 30V DC Max. (Between the output and +V) • Residual voltage: 2V Max. (When load current is 50mA), 1V Max. (When load current is 16mA)
Output Mode	Light-ON / Dark-ON 2 outputs
Protect Circuit	Polarity protection. Surge suppressor. Load short-circuit protection
Response Frequency/Time	3KHz Max. / Light-ON: 20µs Max., Dark-ON: 80µs Max.
Ambient Illumination	1,000 lx max. with fluorescent light on the surface of the receiver
Ambient Temperature Range	Operating: -25°C~+55°C, Storage: -30°C~+80°C (With no icing or condensation)
Ambient Humidity Range	Operating: 5%~85%RH, Storage: 5%~95%RH (With no icing or condensation)
Vibration Resistance	10Hz~2000Hz (Peak acceleration 196m/s ²) 1.5mm double amplitude for 2 hours each in XYZ direction
Shock Resistance	15,000m/s ² (About 1,500G) for 3 times each in XYZ direction
Protection class	IP64(IEC)
Materials	Case: Polybutylene terephthalate (PBT), Emitter/Receiver: Polycarbonate (PC)

Dimension Diagram

Unit: mm

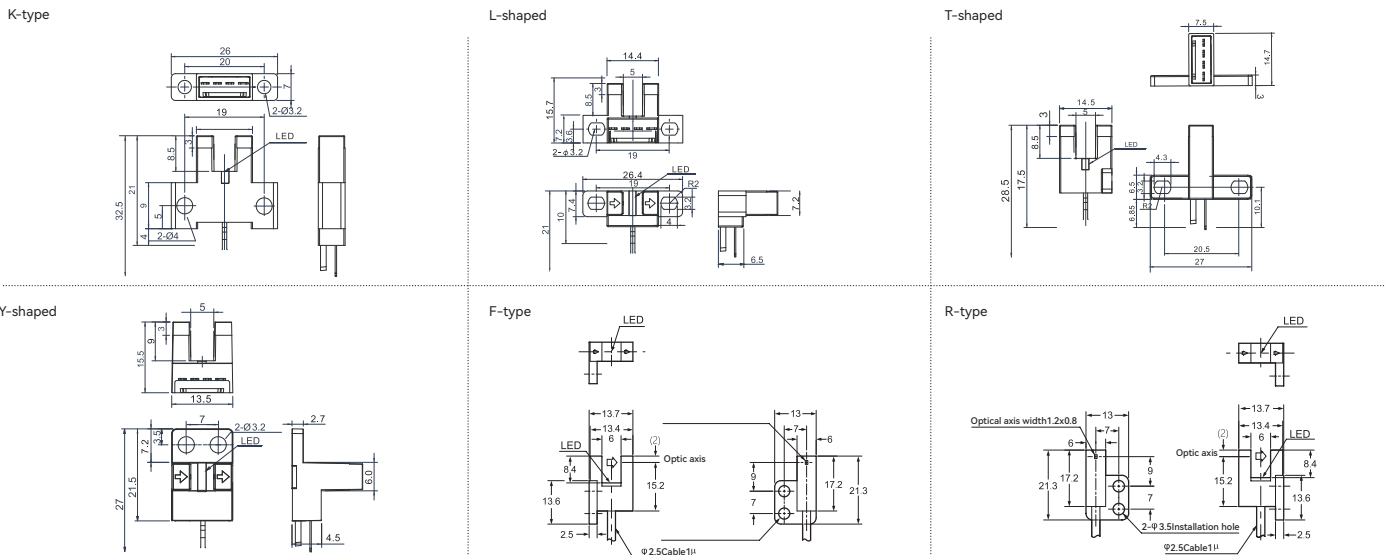

Wiring Diagram

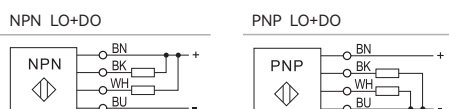



- Feature
- Small size, Response faster more than 1kHz
- Suitable for detect small object
- Anti-light interference strongly



- Feature
- Grooved-type photoelectric sensor with built-in amplifier
- 1ms response time, suitable applying in packaging industry
- 3cm slot width(sensing distance)
- Light-ON/Dark-ON switchable

PW34	-	NC
Series		Output Mode
PW34 Series		NC:NPN
PW35 Series		PC:PNP
PW36 Series		

Detect Type	Connection Method	Sensing Distance	Operation Mode	Type	
Slot-type	Pre-wired cable	10mm	Light-ON/ Dark-ON (Switchable)	NPN	PW34-NC
				PNP	PW34-PC
		15mm		NPN	PW35-NC
				PNP	PW35-PC
		30mm		NPN	PW36-NC
				PNP	PW36-PC

Specifications		
Standard Sensing Object	Opaque object: 3mm	Opaque object: 6mm
Sensing Object Min.	Opaque object: 2mm	Opaque object: 3mm
Light Source (Wavelength)	Infrared LED (950nm)	
Power Supply Voltage	12~24VDC Ripple ±10%max.	
Current Consumption	40mA max.	
Response Time	1ms max.	
Output Control	Light-ON/Dark-ON switchable through wiring	
Protect Circuit	Polarity protection. Load short-circuit protection	
Ambient Illumination	Sunlight: 10000 LX; Incandescent light: 3000 LX	
Ambient Temperature Range	Operating: -25~+55°C	
	Storage: -40~+70°C (With no icing and condensation)	
Ambient Humidity Range	Operating: 35~85%RH	
	Storage: 35~95%RH (with no condensation)	
Insulation Resistance	20MΩ min. (DC500V)	
Dielectric Strength	1500VAC 50/60Hz 1min	
Vibration Resistance	Durability	10~55Hz 1.5mm double amplitude for 2 hours each in X、Y、Z direction
Shock Resistance	Durability	500m/s ² , 10 times each in X、Y、Z direction
Protection class	IEC-IP65	
Materials	Case	ABS
	Lens	Polycarbonate
	Indicate window	Polycarbonate
Connection Method	Pre-wired cable (2m: 3×075mm ²)	

Dimension Diagram Unit: mm

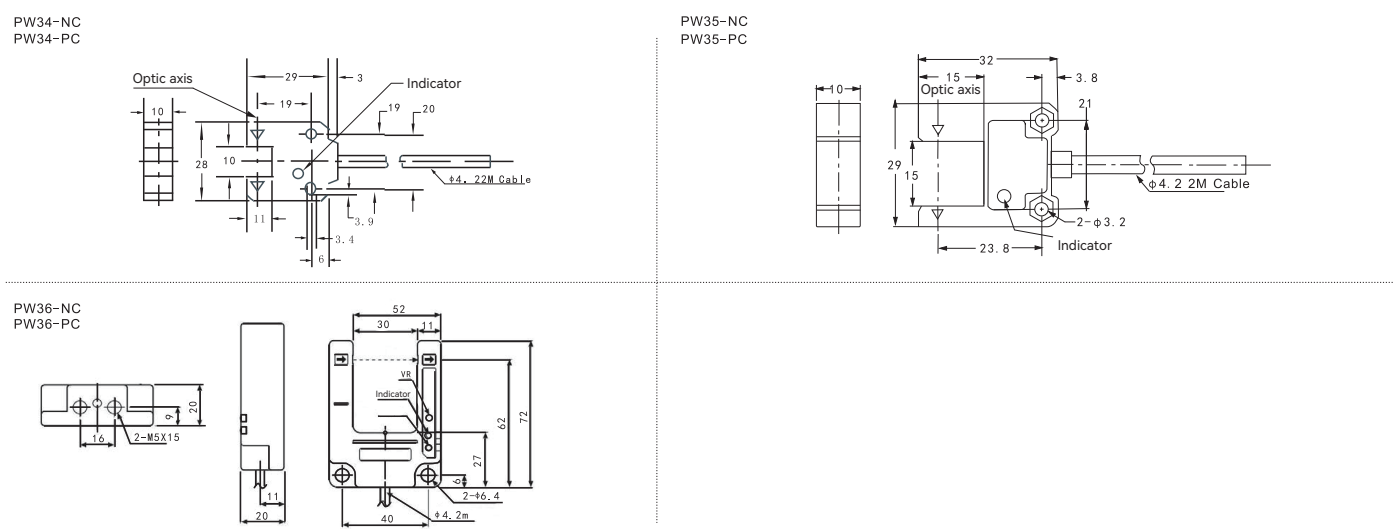

Wiring Diagram

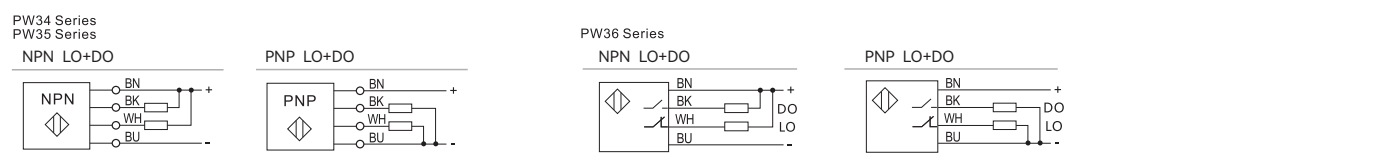



- **Features**
 - Easy for connection, installation and application
 - Stable & reliable detection. Operation indicator
 - Protections: Overload/ Short circuit
 - Flexible cable
 - Degree of protection: IP65
 - Ambient temperature: 0~+55°C

PBN	12	-	B	300	NL
Series PBN Series	Connector Size		Sensing Method	Sensing Distance	Output Mode
	03: M3 04: M4 05: M5 06: M6 08: M8 12: M12 18: M18		B: Diffuse Reflective T: Through beam D: Retro-reflective	030: 30mm 050: 50mm 300: 300mm M01: 1M M05: 5M	NL: NPN LO ND: NPN DO PL: PNP LO PD: PNP DO N: NPN LO+DO P: PNP LO+DO

Model								
NPN NO	PBN03-B030NL	PBN04-B050NL	PBN05-B100NL	PBN06-B150NL	PBN08-B150NL	PBN12-B100NL	PBN12-B300NL	—
NPN NC	PBN03-B030ND	PBN04-B050ND	PBN05-B100ND	PBN06-B150ND	PBN08-B150ND	—	—	PBN12-TM05ND
PNP NO	PBN03-B030PL	PBN04-B050PL	PBN05-B100PL	PBN06-B150PL	PBN08-B150PL	PBN12-B100PL	PBN12-B300PL	—
PNP NC	PBN03-B030PD	PBN04-B050PD	PBN05-B100PD	PBN06-B150PD	PBN08-B150PD	—	—	PBN12-TM05PD
NPN LO+DO	—	—	—	—	—	PBN12-B100N	PBN12-B300N	PBN12-TM05N
PNP LO+DO	—	—	—	—	—	PBN12-B100P	PBN12-B300P	PBN12-TM05P

Specification								
Sensing Method	Diffuse reflective							Through-beam
Sensing Distance ①	30mm	50mm	100mm	150mm	150mm	100mm	300mm	5M
Standard Sensing Object	100×100 White paper							Opaque object: 8mm Max.
Sensitivity Adjustment	Yes							—
Response Frequency ②	100Hz	100Hz	100Hz	100Hz	100Hz	—	—	—
Response Time	5ms	5ms	5ms	5ms	5ms	5ms	5ms	5ms
Differential Travel	15% Max. of sensing distance							
Light Source/Wavelength	Infrared LED (wavelength 880nm)							
Power Supply Voltage (Operating Voltage Range)	12-24VDC, Ripple (p-p) 10% Max. (10-30VDC)							
Current consumption	10mA Max. @24VDC				30mA Max. @24VDC			
Load Current	150mA Max				200mA Max			
Residual Voltage	1.5V Max. (@150mA load, 2M cable)				2.5V Max. (@150mA load, 2M cable)			
Leakage Current	0.01mA Max. @24VDC							
Indicators	Red							
Operation Mode	N-(NPN LO+DO)/NL-(NPN LO)/ND-(NPN DO)/P-(PNP LO+DO)/PL-(PNP LO)/PD-(PNP DO)							
Short Circuit Protection	≥180A							
Protection Circuit	Overload/Short circuit protection.				Power on/Short circuit protection.			
Ambient Temperature Range	Operating / storage: 0~+50°C (with no icing or condensation)				Operating / storage: 0~+55°C (with no icing or condensation)			
Ambient Humidity Range	Operating / storage: 35-85% (with no condensation)							
Temperature Influence	±10% Max. of sensing distance @+25°C in the temperature range							
Ambient Illumination	Incandescent lamp 5000lx Max./ Sunlight 10,000lx Max.							
Insulation Resistance	50MΩ Min. (at 500VDC) between current carrying parts and case							
Dielectric Strength	1000VAC 50/60Hz for 1 minute between current carrying parts and case							
Vibration Resistance	IEC 60947-5-2, Part 7.4.1 / IEC 60947-55-2, Part 7.4.2				10-55Hz 1.5mm Up and down amplitude for 2 hours each in X, Y, Z direction			
Shock Resistance	500 m/s ² 10 times each in X, Y and Z directions							
Degree of Protection	IEC standards EN60529:IP65							
Connection Method	Pre-wired 2M							
Weight (Packed state)	~12g	~13g	~16g	~20g	~25g	~60g	~60g	~120g
Materials of Case	Stainless Steel							
Materials of Sensing Surface	Filter Glass							
Accessories	Clamping nuts. Mounting bracket available(optional)							

① The data of sensing distance is based on the standard object. Other object please refer to "Relative dielectric constant"
 ② Response frequency is an average of value. The measure condition is as follow: standard object and the setting distance of half sensing distance.

Dimension Diagram Unit: mm

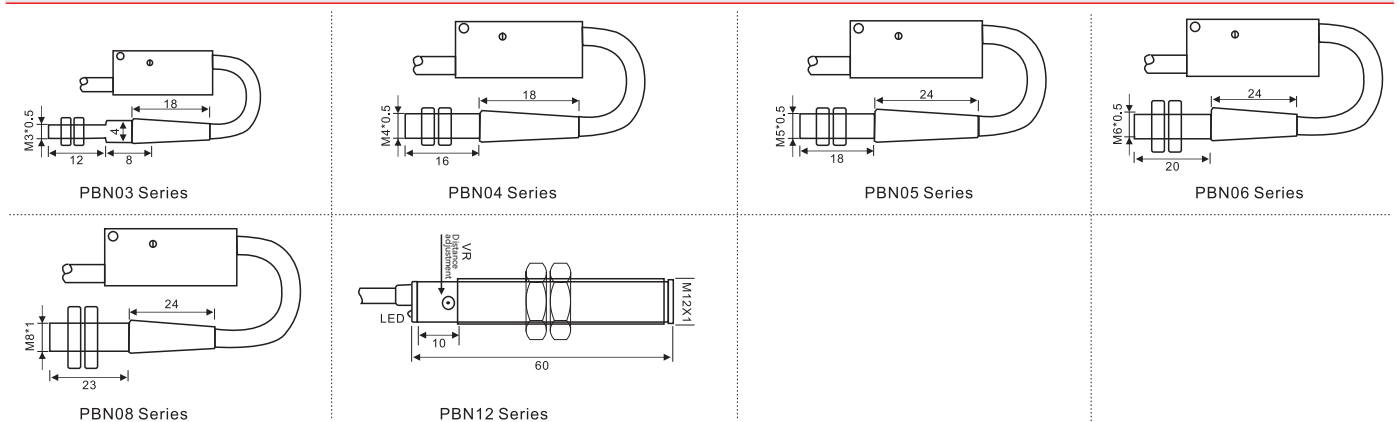

Wiring Diagram

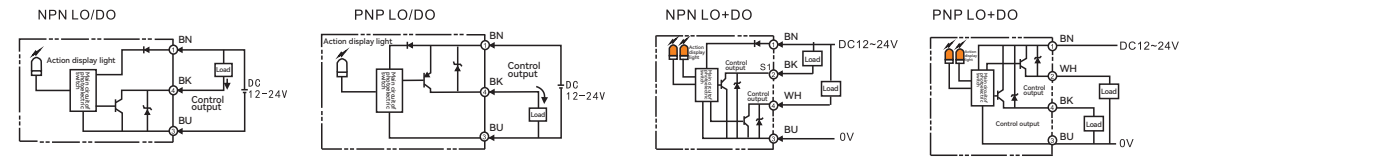



- Features
 - Easy for connection, installation and application
 - Stable & reliable detection. Operation indicator
 - Protections: Overload/ Short circuit
 - Flexible cable
 - Degree of protection: IP65
 - Ambient temperature: 0~+55°C

PBN	18	-	B	300	NL
Series	Connector Size		Sensing Method	Sensing Distance	Output Mode
PBN Series	03: M3 04: M4 05: M5 06: M6 08: M8 12: M12 18: M18		B: Diffuse Reflective T: Through beam D: Retro-reflective	030: 30mm 050: 50mm 300: 300mm M01: 1M M05: 5M	NL: NPN LO ND: NPN DO PL: PNP LO PD: PNP DO N: NPN LO+DO P: PNP LO+DO

Model						
NPN NO	PBN18-B300NL	PBN18-B500NL	PBN18-BM01NL	—	—	—
NPN NC	—	—	—	PBN18-TM15ND	PBN18-TM15ND	PBN18-DM02ND
PNP NO	PBN18-B300PL	PBN18-B500PL	PBN18-BM01PL	—	—	—
PNP NC	—	—	—	PBN18-TM15PD	PBN18-TM15PD	PBN18-DM02ND
NPN LO+DO	PBN18-B300N	PBN18-B500N	PBN18-BM01N	PBN18-TM15N	PBN18-TM15N	PBN18-DM02N
PNP LO+DO	PBN18-B300P	PBN18-B500P	PBN18-BM01P	PBN18-TM15P	PBN18-TM15P	PBN18-DM02P

Specification						
Sensing Method	Diffuse reflective			Opposite type		Regressive reflex type
Sensing Distance ①	300mm	500mm	1000mm	5M	15M	2M
Standard Sensing Object	200×200 White paper			Opaque object: 8mm Max.		Reflector
Sensitivity Adjustment	Yes			No		Yes
Response Time	5ms	5ms	5ms	5ms	5ms	5ms
Differential Travel	15% Max. of sensing distance					
Light Source/Wavelength	Infrared LED (wavelength 880nm)					
Power Supply Voltage (Operating Voltage Range)	12-24VDC, Ripple (p-p) 10% Max. (10-30VDC)					
Current consumption	30mA Max. @24VDC					
Load Current	200mA Max					
Residual Voltage	2.5V Max. (@150mA load, 2M cable)					
Leakage Current	0.01mA Max. @24VDC					
Indicators	Red					
Operation Mode	N-(NPN LO+DO)/NL-(NPN LO)/ND-(NPN DO)/P-(PNP LO+DO)/PL-(PNP LO)/PD-(PNP DO)					
Protection Circuit	Short circuit protection.					
Ambient Temperature Range	Operating / storage: 0~+55°C (with no icing or condensation)					
Ambient Humidity Range	Operating / storage: 35-85% (with no condensation)					
Temperature Influence	±10% Max. of sensing distance @+25°C in the temperature range					
Ambient Illumination	Incandescent lamp 5000lx Max./ Sunlight 10,000lx Max.					
Insulation Resistance	50MΩ Min. (at 500VDC) between current carrying parts and case					
Dielectric Strength	1000VAC 50/60Hz for 1 minute between current carrying parts and case					
Vibration Resistance	10~55Hz 1.5mm Up and down amplitude for 2 hours each in X, Y, Z direction					
Shock Resistance	500 m/s ² 10 times each in X, Y and Z directions					
Degree of Protection	IEC standards EN60529:IP66					
Connection Method	Pre-wired 2M					
Weight (Packed state)	~120g	~120g	~120g	~240g	~240g	~120g
Materials of Case	Nickel-plated Brass					
Materials of Sensing Surface	Filter Glass					
Accessories	Clamping nuts. Mounting bracket available(optional)					

- ① Sensing distance, range ±10%.
- ② Response frequency is an average value. Measure condition is as follow: standard sensing object, a setting distance of half the sensing distance.

Dimension Diagram Unit: mm

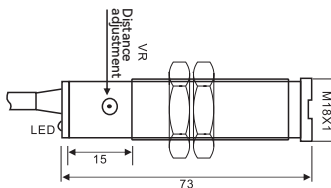

PBN18 Series

Wiring Diagram

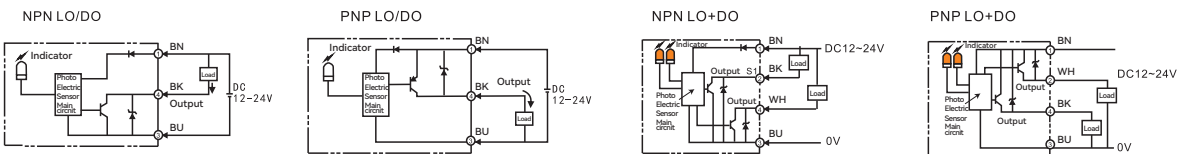



- Features
- Easy for connection, installation and application
- Stable & reliable detection. Operation indicator
- Small light spot: 2~3mm
- Visible light of small spot realized
- Position confirmed by naked eye
- Flexible cable
- Degree of protection: IP67

PBL	04	A	-	B	300	NL
Series PBL Series	Size 03: M3 04: M4 05: M5 06: M6 08: M8 12: M12 18: M18	How it appears Non: General A: L-shaped outgoing line		Sensing Method B: Diffuse Reflective T: Through beam D: Retro-reflective	Sensing Distance 030: 30mm 050: 50mm 300: 300mm M01: 1M M05: 5M	Output Mode NL: NPN LO ND: NPN DO PL: PNP LO PD: PNP DO N: NPN LO+DO P: PNP LO+DO

Model	PBL03-B030NL		PBL03-TM20NL		PBL04-B050NL		PBL04-TM20NL		PBL04A-B050NL		PBL04A-TM20NL		PBL05-B100NL		PBL05-TM20NL	
NPN NO	PBL03-B030NL		PBL03-TM20NL		PBL04-B050NL		PBL04-TM20NL		PBL04A-B050NL		PBL04A-TM20NL		PBL05-B100NL		PBL05-TM20NL	
NPN NC	PBL03-B030ND		PBL03-TM20ND		PBL04-B050ND		PBL04-TM20ND		PBL04A-B050ND		PBL04A-TM20ND		PBL05-B100ND		PBL05-TM20ND	
PNP NO	PBL03-B030PL		PBL03-TM20PL		PBL04-B050PL		PBL04-TM20PL		PBL04A-B050PL		PBL04A-TM20PL		PBL05-B100PL		PBL05-TM20PL	
PNP NC	PBL03-B030PD		PBL03-TM20PD		PBL04-B050PD		PBL04-TM20PD		PBL04A-B050PD		PBL04A-TM20PD		PBL05-B100PD		PBL05-TM20PD	

Specification	Diffuse reflective	Through-beam	Diffuse reflective	Through-beam	Diffuse reflective	Through-beam	Diffuse reflective	Through-beam
Sensing Method	Diffuse reflective	Through-beam	Diffuse reflective	Through-beam	Diffuse reflective	Through-beam	Diffuse reflective	Through-beam
Sensing Distance ①	30mm	20mm	50mm	20mm	50mm	20mm	100mm	20mm
Standard Sensing Object	100×100 White paper	Opaque object: 8mm Max.	100×100 White paper	Opaque object: 8mm Max.	100×100 White paper	Opaque object: 8mm Max.	100×100 White paper	Opaque object: 8mm Max.
Spot diameter								
Sensitivity Adjustment	Yes	No	Yes	No	Yes	No	Yes	-
Response Frequency ②	100Hz	100Hz	100Hz	100Hz	100Hz	100Hz	100Hz	100Hz
Response Time	5ms	5ms	5ms	5ms	5ms	5ms	5ms	5ms
Differential Travel	15% Max. of sensing distance							
Light Source/Wavelength	Visible LED (wavelength 660nm)							
Power Supply Voltage (Operating Voltage Range)	12-24VDC, Ripple (p-p) 10% Max. (10-30VDC)							
Current consumption	10mA Max. @24VDC							
Load Current	150mA Max							
Residual Voltage	1.5V Max. (@150mA load, 2M cable)							
Leakage Current	0.01mA Max. @24VDC							
Indicators	Red							
Operation Mode	N-(NPN LO+DO)/NL-(NPN LO)/ND-(NPN DO)/P-(PNP LO+DO)/PL-(PNP LO)/PD-(PNP DO)							
Short Circuit Protection	≥180A							
Protection Circuit	Overload/Short circuit protection.							
Ambient Temperature Range	Operating / storage: 0~+55°C (with no icing or condensation)							
Ambient Humidity Range	Operating / storage: 35-85% (with no condensation)							
Temperature Influence	±10% Max. of sensing distance @+25°C in the temperature range							
Insulation Resistance	50MΩ Min. (at 500VDC) between current carrying parts and case							
Dielectric Strength	1000VAC 50/60Hz for 1 minute between current carrying parts and case							
Vibration/Shock Resistance	IEC 60947-5-2, Part 7.4.1 / IEC 60947-5-2, Part 7.4.2							
EMC	RFI>3V/M / EFT>1KV / ESD>4KV(contact)							
Degree of Protection	IEC standards EN60529:IP66							
Connection Method	Pre-wired 2M							
Weight (Packed state)	~12g	~25g	~16g	~35g	~16g	~35g	~30g	~60g
Materials of Case	Stainless Steel							
Materials of Sensing Surface	Filter Glass							
Accessories	Clamping nuts.							

① Sensing distance, range ±10%.

② Response frequency is an average value. Measure condition is as follow: standard sensing object, a setting distance of half the sensing distance.

Dimension Diagram

Unit: mm

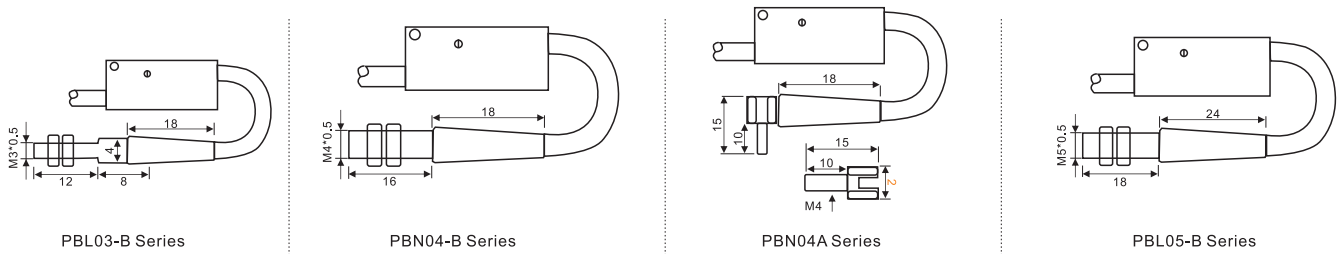

Wiring Diagram

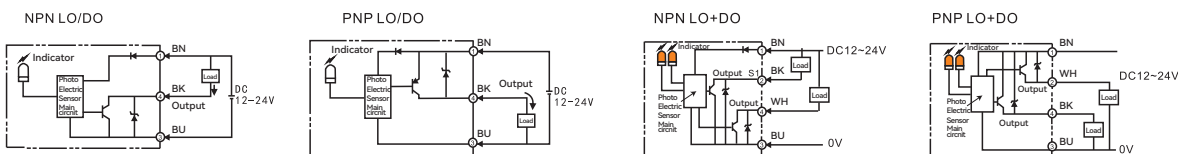



- Features
 - Easy for connection, installation and application
 - Stable & reliable detection. Operation indicator
 - Small light spot: 2~3mm
 - Visible light of small spot realized
 - Position confirmed by naked eye
 - Flexible cable
 - Degree of protection: IP67

PBL	04	A	-	B	300	NL
Series PBL Series	Size 03: M3 04: M4 05: M5 06: M6 08: M8 12: M12 18: M18	How it appears Non: General A: L-shaped outgoing line		Sensing Method B: Diffuse Reflective T: Through beam D: Retro-reflective	Sensing Distance 030: 30mm 050: 50mm 300: 300mm M01: 1M M05: 5M	Output Mode NL: NPN LO ND: NPN DO PL: PNP LO PD: PNP DO N: NPN LO+DO P: PNP LO+DO

Model						
NPN NO	PBL06-B150NL	PBL06-TM20NL	PBL06A-B100NL	PBL06A-TM20NL	PBL08-B050NL	PBL08-TM30NL
NPN NC	PBL06-B150ND	PBL06-TM20ND	PBL06A-B100ND	PBL06A-TM20ND	PBL08-B050ND	PBL08-TM30ND
PNP NO	PBL06-B150PL	PBL06-TM20PL	PBL06A-B100PL	PBL06A-TM20PL	PBL08-B050PL	PBL08-TM30PL
PNP NC	PBL06-B150PD	PBL06-TM20PD	PBL06A-B100PD	PBL06A-TM20PD	PBL08-B050PD	PBL08-TM30PD

Specification						
Sensing Method	Diffuse reflective	Through-beam	Diffuse reflective	Through-beam	Diffuse reflective	Through-beam
Sensing Distance ①	150mm	20M	100mm	20M	150mm	30M
Standard Sensing Object	100×100 White paper	Opaque object: 8mm Max.	100×100 White paper	Opaque object: 8mm Max.	100×100 White paper	Opaque object: 8mm Max.
Spot diameter	1~2mm	1~2mm	1~2mm	1~2mm	2mm	2mm
Sensitivity Adjustment	Yes	No	Yes	No	Yes	No
Response Frequency ②	100Hz	100Hz	100Hz	100Hz	100Hz	100Hz
Response Time	5ms	5ms	5ms	5ms	5ms	5ms
Differential Travel	15% Max. of sensing distance					
Light Source/Wavelength	Visible LED (wavelength 660nm)					
Power Supply Voltage (Operating Voltage Range)	12-24VDC, Ripple (p-p) 10% Max. (10-30VDC)					
Current consumption	10mA Max. @24VDC					
Load Current	150mA Max					
Residual Voltage	1.5V Max. (@150mA load, 2M cable)					
Leakage Current	0.01mA Max. @24VDC					
Indicators	Red					
Operation Mode	N-(NPN LO+DO)/NL-(NPN LO)/ND-(NPN DO)/P-(PNP LO+DO)/PL-(PNP LO)/PD-(PNP DO)					
Short Circuit Protection	≥180A					
Protection Circuit	Overload/Short circuit protection.					
Ambient Temperature Range	Operating / storage: 0~+55°C (with no icing or condensation)					
Ambient Humidity Range	Operating / storage: 35-85% (with no condensation)					
Temperature Influence	±10% Max. of sensing distance @+25°C in the temperature range					
Insulation Resistance	50MΩ Min. (at 500VDC) between current carrying parts and case					
Dielectric Strength	1000VAC 50/60Hz for 1 minute between current carrying parts and case					
Vibration/Shock Resistance	IEC 60947-5-2, Part 7.4.1 / IEC 60947-5-2, Part 7.4.2					
EMC	RFI>3V/M / EFT>1KV / ESD>4KV(contact)					
Degree of Protection	IEC standards EN60529:IP66					
Connection Method	Pre-wired 2M					
Weight (Packed state)	~30g	~60g	~30g	~60g	~35g	~70g
Materials of Case	Stainless Steel				Nickel-plated Brass	
Materials of Sensing Surface	Filter Glass					
Accessories	Clamping nuts.					

① Sensing distance, range ±10%

② Response frequency is an average value. Measure condition is as follow: standard sensing object, a setting distance of half the sensing distance.

Dimension Diagram

Unit: mm

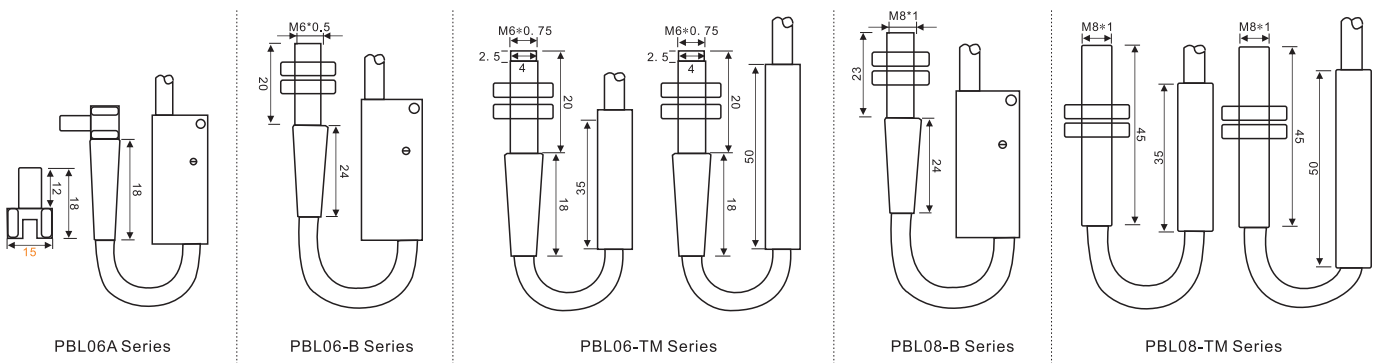

Wiring Diagram

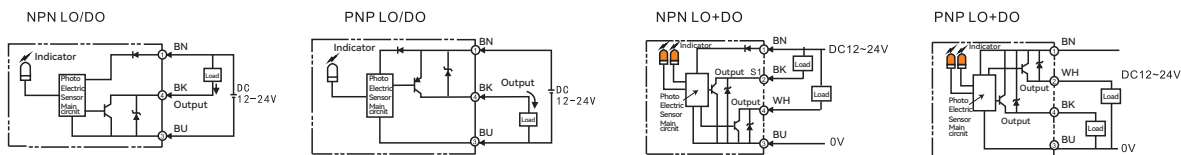



- Features
 - Easy for connection, installation and application
 - Stable & reliable detection. Operation indicator
 - Small light spot: 2~3mm
 - Visible light of small spot realized
 - Position confirmed by naked eye
 - Flexible cable
 - Degree of protection: IP67

PBL	12	-	B	200	NL
Series	Size		Sensing Method	Sensing Distance	Output Mode
PBL Series	03:M3 04:M4 05:M5 06:M6 08:M8 12:M12 18:M18		B: Diffuse Reflective T: Through beam D: Retro-reflective	030:30mm 050:50mm 300:300mm M01:1M M05:5M	NL: NPN LO ND: NPN DO PL: PNP LO PD: PNP DO N: NPN LO+DO P: PNP LO+DO

Model				
NPN NO	PBL12-B200NL	—	PBL18-B300NL	—
NPN NC	—	PBL12-TM50ND	—	PBL18-TM50ND
PNP NO	PBL12-B200PL	—	PBL18-B300PL	—
PNP NC	—	PBL12-TM50PD	—	PBL18-TM50ND
NPN LO+DO	PBL12-B200N	PBL12-TM50N	PBL18-B300N	PBL18-TM50N
PNP LO+DO	PBL12-B200P	PBL12-TM50P	PBL18-B300P	PBL18-TM50P

Specification				
Sensing Method	Diffuse reflective	Through-beam	Diffuse reflective	Through-beam
Sensing Distance ①	200mm	50M	300mm	50M
Standard Sensing Object	100×100 White paper	Opaque object: 8mm Max.	100×100 White paper	Opaque object: 8mm Max.
Spot diameter	2~3mm	2~3mm	2~3mm	2~3mm
Sensitivity Adjustment	Yes	No	Yes	No
Response Frequency ②	100Hz	100Hz	100Hz	100Hz
Response Time	5ms	5ms	5ms	5ms
Differential Travel	15% Max. of sensing distance			
Light Source/Wavelength	Visible LED (wavelength 660nm)			
Power Supply Voltage (Operating Voltage Range)	12-24VDC, Ripple (p-p) 10% Max. (10-30VDC)			
Current consumption	10mA Max. @24VDC, Through-beam, receiving end: max 11mA.			
Load Current	150mA Max			
Residual Voltage	1.5V Max. (@150mA load, 2M cable)			
Leakage Current	0.01mA Max. @24VDC			
Indicators	Red			
Operation Mode	N-(NPN LO+DO)/NL-(NPN LO)/ND-(NPN DO)/P-(PNP LO+DO)/PL-(PNP LO)/PD-(PNP DO)			
Short Circuit Protection	≥180A			
Protection Circuit	Overload/Short circuit protection.			
Ambient Temperature Range	Operating / storage: 0~+55°C (with no icing or condensation)			
Ambient Humidity Range	Operating / storage: 35-85% (with no condensation)			
Temperature Influence	±10% Max. of sensing distance @+25°C in the temperature range			
Insulation Resistance	50MΩ Min. (at 500VDC) between current carrying parts and case			
Dielectric Strength	1000VAC 50/60Hz for 1 minute between current carrying parts and case			
Vibration/Shock Resistance	IEC 60947-5-2, Part7.4.1 / IEC 60947-55-2, Part7.4.2			
EMC	RFI>3V/M / EFT>1KV / ESD>4KV(contact)			
Degree of Protection	IEC standards EN60529:IP66			
Connection Method	Pre-wired 2M			
Weight (Packed state)	~65g	~130g	~80g	~160g
Materials of Case	Nickel-plated Brass			
Materials of Sensing Surface	Filter Glass			
Accessories	Clamping nuts.			

① Sensing distance, range ±10%.
 ② Response frequency is an average value. Measure condition is as follow: standard sensing object, a setting distance of half the sensing distance.

Dimension Diagram Unit: mm

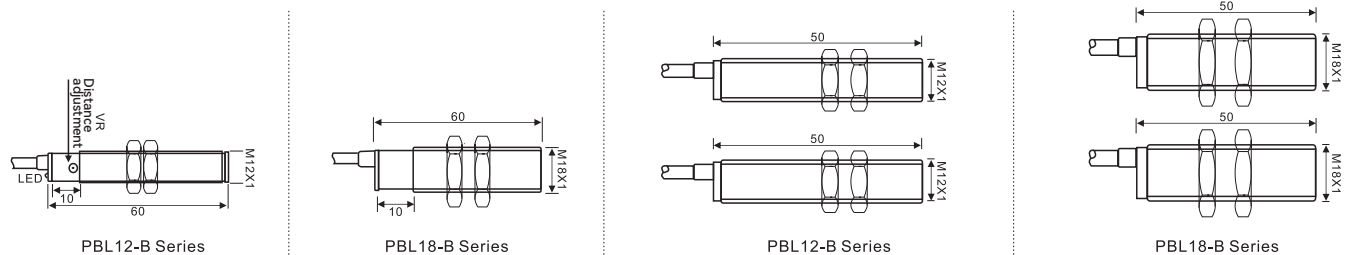

Wiring Diagram

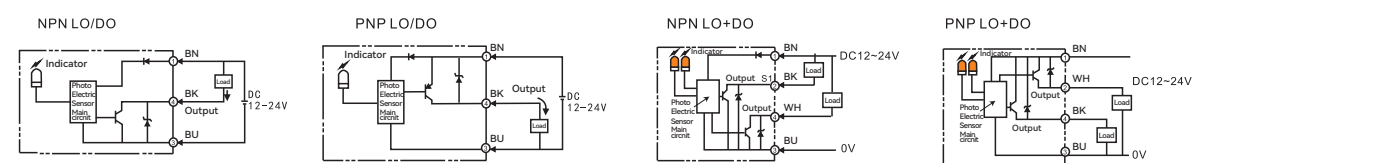



- Features
 - Easy for connection, installation and application
 - Stable & reliable detection. Operation indicator
 - Protections: Overload/ Short circuit
 - Flexible cable
 - Degree of protection: IP65
 - Ambient temperature: 0~+55°C

PC22	-	B	300	NL
Series PC22 Series		Sensing Method B: Diffuse Reflective T: Through beam D: Retro-reflective	Sensing Distance 030:30mm 050:50mm 300:300mm M01:1M M05:5M	Output Mode NL: NPN LO ND: NPN DO PL: PNP LO PD: PNP DO N: NPN LO+DO P: PNP LO+DO

Model								
NPN NO	—	PC22-B200NL	PC22-B300NL	—	PC22-DM02NL	—	PC22-TM05NL	—
NPN NC	—	PC22-B200ND	PC22-B300ND	—	PC22-DM02ND	—	PC22-TM05ND	—
PNP NO	—	PC22-B200PL	PC22-B300PL	—	PC22-DM02PL	—	PC22-TM05PL	—
PNP NC	—	PC22-B200PD	PC22-B300PD	—	PC22-DM02PD	—	PC22-TM05PD	—
NPN LO+DO	PC21-B100N	—	—	PC21-B400N	—	PC21-DM03N	—	PC21-TM12N
PNP LO+DO	PC21-B100P	—	—	PC21-B400P	—	PC21-DM03P	—	PC21-TM12P

Specification								
Sensing Method	Diffuse reflective				Retro-reflective		Through-beam	
Sensing Distance ①	100mm	200mm	300mm	400mm	2M	3M	5M	12M
Standard Sensing Object	100×100 White paper				Reflector		Opaque object: 8mm Max.	
Sensitivity Adjustment	Yes							
Response Time	1ms	5ms	5ms	1ms	5ms	1ms	5ms	5ms
Differential Travel	20% Max. of sensing distance							
Light Source/Wavelength	PC22 invisible infrared light (880nm); PC21 Visible infrared light (650nm) PC21 Series							
Power Supply Voltage (Operating Voltage Range)	12-24VDC, Ripple (p-p) 10% Max. (10-30VDC)							
Current consumption	30mA Max. @24VDC							
Load Current	100mA Max	200mA Max	200mA Max	100mA Max	200mA Max	100mA Max	200mA Max	100mA Max
Residual Voltage	1.5V Max. (@150mA load, 2M cable)							
Leakage Current	0.01mA Max. @24VDC							
Indicators	Red							
Operation Mode	N-(NPN LO+DO)/NL-(NPN LO)/ND-(NPN DO)/P-(PNP LO+DO)/PL-(PNP LO)/PD-(PNP DO)							
Protection Circuit	Overload/Short circuit protection.							
Ambient Temperature Range	Operating / storage: 0~+55°C (with no icing or condensation)							
Ambient Humidity Range	Operating / storage: 35-85% (with no condensation)							
Temperature Influence	±10% Max. of sensing distance @+25°C in the temperature range							
Insulation Resistance	50MΩ Min. (at 500VDC) between current carrying parts and case							
Dielectric Strength	1000VAC 50/60Hz for 1 minute between current carrying parts and case							
Vibration Resistance	10~55Hz 1.5mm Up and down amplitude for 2 hours each in X, Y, Z direction							
Shock Resistance	500 m/s ² 10 times each in X, Y and Z directions							
Degree of Protection	IEC standards EN60529:IP65							
Connection Method	Pre-wired 2M							
Weight (Packed state)	~50g						~100g	
Materials of Case	PBT	ABS	ABS	PBT	ABS	PBT	ABS	PBT
Materials of Sensing Surface	Acrylic Resin	Filter Glass	Filter Glass	Acrylic Resin	Filter Glass	Acrylic Resin	Filter Glass	Acrylic Resin
Accessories	Clamping nuts. Mounting bracket available(optional)							

① Sensing distance, range ±10%.
 ② Response frequency is an average value. Measure condition is as follow: standard sensing object, a setting distance of half the sensing distance.

Dimension Diagram Unit: mm

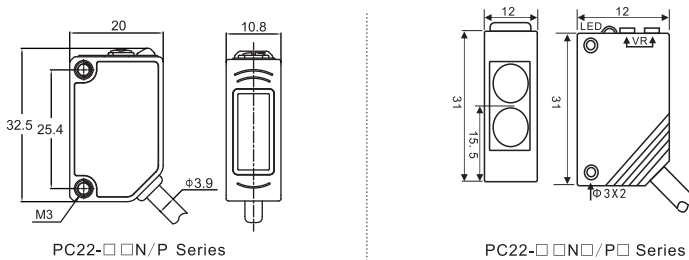

Wiring Diagram

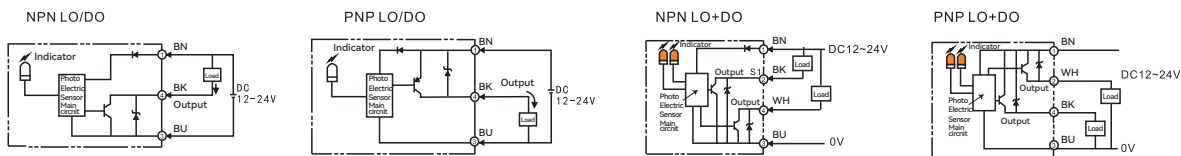



- **Features**
 - Easy for connection, installation and application
 - Stable & reliable detection. Operation indicator
 - Small light spot: 2~3mm
 - Visible light of small spot realized
 - Position confirmed by naked eye
 - Flexible cable
 - Degree of protection: IP55

PC27	-	B	300	NL
Series PC27 Series		Sensing Method B: Diffuse Reflective T: Through beam D: Retro-reflective	Sensing Distance 100:100mm 200:200mm 300:300mm M08:8M M30:30M	Output Mode NL: NPN LO ND: NPN DO PL: PNP LO PD: PNP DO N: NPN LO+DO P: PNP LO+DO

Model					
NPN NO	PC27-B200NL	PC27-B300NL	—	PC27-DM08NL	PC27-TM30NL
NPN NC	PC27-B200ND	PC27-B300ND	—	PC27-DM08ND	PC27-TM30ND
PNP NO	PC27-B200PL	PC27-B200PL	—	PC27-DM08PL	PC27-TM30PL
PNP NC	PC27-B200ND	PC27-B300ND	—	PC27-DM08ND	PC27-TM30ND
NPN LO+DO	—	—	PC27-B500N	—	—
PNP LO+DO	—	—	—	—	—

Specification						
Sensing Method	Diffuse reflective				Retro-reflective	Through-beam
Sensing Distance ①	100mm	200mm	300mm	500mm	8M	30M
Standard Sensing Object	100×100 White paper				Reflector	Opaque object: 8mm Max.
Spot diameter	1~2mm	2~3mm	2~3mm	2~3mm	2~3mm	2~3mm
Sensitivity Adjustment	Yes					No
Response Time	1ms	5ms	5ms	1ms	5ms	5ms
Differential Travel	20% Max. of sensing distance					
Light Source/Wavelength	Visible LED (wavelength 660nm)					
Power Supply Voltage (Operating Voltage Range)	12-24VDC, Ripple (p-p) 10% Max. (10-30VDC)					
Current consumption	max 45mA	max 10mA		max 10mA	max 45mA	Launchu<10mA, Receiveu<11mA
Load Current	100mA Max	150mA Max		100mA Max	150mA Max	150mA Max
Residual Voltage	3V Max. (@100mA load, 2M cable)					
Leakage Current	0.01mA Max. @24VDC					
Indicators	Red					
Operation Mode	N-(NPN LO+DO)/NL-(NPN LO)/ND-(NPN DO)/P-(PNP LO+DO)/PL-(PNP LO)/PD-(PNP DO)					
Protection Circuit	Overload/Short circuit protection.					
Ambient Temperature Range	Operating / storage: 0~+50°C (with no icing or condensation)					
Ambient Humidity Range	Operating / storage: 35-85% (with no condensation)					
Temperature Influence	±10% Max. of sensing distance @+25°C in the temperature range					
Insulation Resistance	50MΩ Min. (at 500VDC) between current carrying parts and case					
Dielectric Strength	1000VAC 50/60Hz for 1 minute between current carrying parts and case					
Vibration/Shock Resistance	IEC 60947-5-2, Part7.4.1 / IEC 60947-5-2, Part7.4.2					
EMC	RFI>3V/M / EFT>1KV / ESD>4KV(contact)					
Degree of Protection	IEC standards EN60529:IP55					
Connection Method	Pre-wired 2M					
Weight (Packed state)	~50g				~100g	
Materials of Case	ASA PMMA	ABS	ABS	ASA PMMA	ABS	ABS
Materials of Sensing Surface	PMMA	Filter Glass	Filter Glass	PMMA	Filter Glass	Filter Glass
Accessories	Clamping nuts.					

① Sensing distance, range ±10%.

② Response frequency is an average value. Measure condition is as follow: standard sensing object, a setting distance of half the sensing distance.

Dimension Diagram

Unit: mm

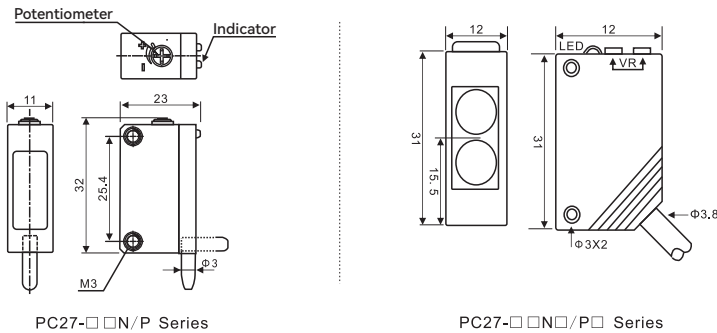

Wiring Diagram

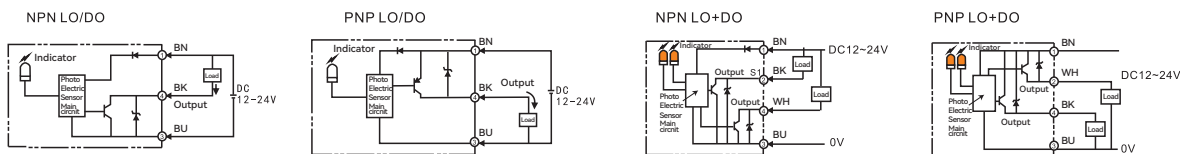



PC31	B	M01	R
Series PC31 Series	Sensing Method B: Diffuse Reflective T: Through beam D: Retro-reflective	Sensing Distance 500:500mm 1M5:1.5M M04:4M M15:15M	Output Mode R: Relay output

- Features**
- High precise sensitivity adjustor(Diffuse reflective)
 - Red LED light source
 - Relay contact output
 - Reverse polarity/Short circuit protection
 - Surge suppressor
 - Flexible cable/ Oil resistance

Model			
Relay	PC31-BM01R	PC31-DM07R-3	PC31-TM20R

Specification			
Sensing Method	Diffuse reflective	Retro-reflective	Through-beam
Light Source/Wavelength	Red LED (Visible)		
Sensing Distance	1M	7M	20M
Standard Sensing Object	Opaque object		
Differential Travel	20% Max. of sensing distance	—	—
Sensitivity Adjustment	Yes	—	—
Response Time	1.0ms Max.		
Power Supply Voltage (Operating Voltage Range)	12-24VDC, Ripple (p-p) 10% Max. (10-30VDC)		
Current consumption	5mA Max. @NPN. 7mA Max. @PNP 100mA Max. @12VDC, 200mA Max.@24VDC		
Residual Voltage	1V Max.		
Ambient Illumination	Incandescent lamp 3000lx Max.		
Protection Circuit	Reverse Polarity/Overload/Short circuit protection/ Surge suppressor		
Ambient Temperature Range	Operating -25~+70°C / storage: -40~+80°C (with no icing or condensation)		
Ambient Humidity Range	Operating 45~85% / storage: 35-95% (with no icing or condensation)		
Insulation Resistance	20MΩ Min. (at 500VDC) between current carrying parts and case		
Dielectric Strength	1000VAC 50/60Hz for 1 minute between current carrying parts and case		
Vibration Resistance	10-55Hz 1.5mm double amplitude for 2 hours each in X, Y, Z directions		
Shock Resistance	500 m/s ² 10 times each in X, Y and Z directions		
Degree of Protection	IEC standards: IP50		
Materials of Case/Sensing Surface	Case: PBT/ Sensing Surface: Acrylate resin		
Connection Method	Pre-wired 2M		
Accessories	—	Reflector	—

Dimension Diagram Unit: mm

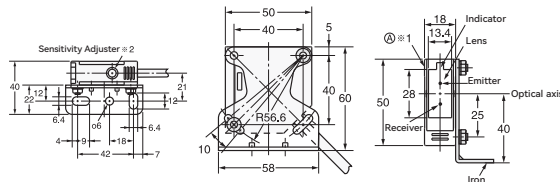

PC31-BM01R/PC31-DM07R-3

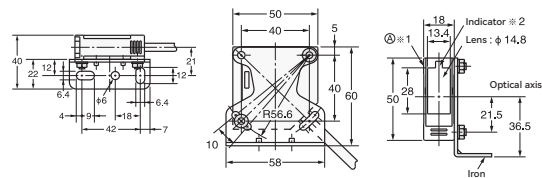

PC31-TM20R

Wiring Diagram

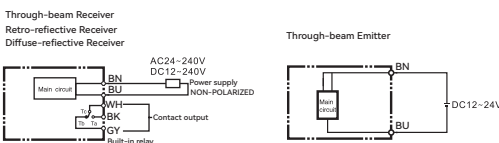

PC32	B	300	NL
Series PC31 Series PC32 Series	Sensing Method B: Diffuse Reflective T: Through beam D: Retro-reflective	Sensing Distance 500:500mm 1M5:1.5M M04:4M M15:15M	Output Mode NL: NPN LO ND: NPN DO PL: PNP LO PD: PNP DO

- Features**
- Easy for connection, installation and application
 - Stable & reliable detection, Operation indicator
 - Protections: Surge suppressor/ Short circuit
 - Flexible cable
 - Degree of protection: IP65
 - Ambient temperature: 0~+55°C

Mode				
NPN LO	PC32-B500NL	PC32-B1M5NL	PC32-DM04NL	PC32-TM15NL
NPN DO	PC32-B500ND	PC32-B1M5ND	PC32-DM04ND	PC32-TM15ND
PNP LO	PC32-B500PL	PC32-B1M5PL	PC32-DM04PL	PC32-TM15PL
PNP DO	PC32-B500PD	PC32-B1M5PD	PC32-DM04PD	PC32-TM15PD

Specification				
Sensing Method	Diffuse reflective	Retro-reflective	Through-beam	
Sensing Distance ①	500mm	1.5M	4M	15M
Standard Sensing Object	200 × 200 White paper		Reflector	Opaque object: 8mm Max.
Sensitivity Adjustment	Yes			
Response Time	5ms			
Differential Travel	15% Max. of sensing distance			
Light Source/Wavelength	Infrared LED (wavelength 880nm)			
Power Supply Voltage (Operating Voltage Range)	12-24VDC, Ripple (p-p) 10% Max. (10-30VDC)			
Current consumption	10mA Max. @24VDC			
Load Current	200mA Max			
Residual Voltage	2.5V Max. (@200mA load, 2M cable)			
Leakage Current	0.05mA Max. @24VDC			
Indicators	Red			
Operation Mode	N-(NPN LO+DO)/NL-(NPN LO)/ND-(NPN DO)/P-(PNP LO+DO) /PL-(PNP LO)/PD-(PNP DO)			
Protection Circuit	Power on/Short circuit protection.			
Ambient Temperature Range	Operating / storage: 0~+55°C (with no icing or condensation)			
Ambient Humidity Range	Operating / storage: 35-85% (with no condensation)			
Temperature Influence	±10% Max. of sensing distance @+25°C in the temperature range			
Ambient Illumination	Incandescent lamp 3000lx Max.			
Insulation Resistance	50MΩ Min. (at 500VDC) between current carrying parts and case			
Dielectric Strength	1000VAC 50/60Hz for 1 minute between current carrying parts and case			
Vibration Resistance	10-55Hz 1.5mm Up and down amplitude for 2 hours each in X, Y, Z direction			
Shock Resistance	500 m/s ² 10 times each in X, Y and Z directions			
Degree of Protection	IEC standards EN60529:IP65			
Connection Method	Pre-wired 2M			
Weight (Packed state)	~100g			~200g
Materials of Case	ABS			
Materials of Sensing Surface	Filter Glass			
Accessories	Clamping nuts. Mounting bracket available(optional)			

- ① Sensing distance, range ±10%.
② Response frequency is an average value. Measure condition is as follow: standard sensing object, a setting distance of half the sensing distance.

Dimension Diagram Unit: mm

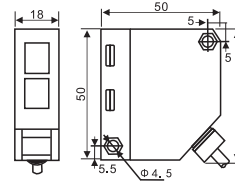

Wiring Diagram

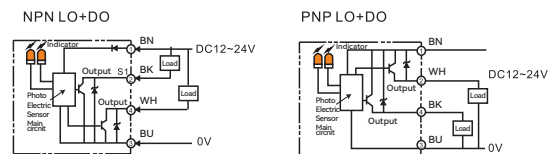
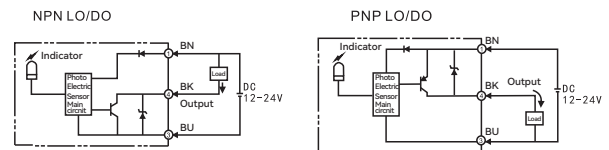

PCD	-	B	300	NL
Series PCD Series		Sensing Method B: Diffuse Reflective T: Through beam D: Retro-reflective	Sensing Distance 100:100mm M05:5M	Output Mode NL:NPN LO ND:NPN DO PL:PNP LO PD:PNP DO



- Features**
- Ultra small size. Easily install
 - Reverse polarity/Short circuit protection
 - Surge suppressor
 - Flexible cable/Oil resistance

Model		
NPN LO	PCD-B100NL	PCD-7M02NL
NPN DO	PCD-B100ND	PCD-7M02ND
PNP LO	PCD-B100PL	PCD-7M02PL
PNP DO	PCD-B100PD	PCD-7M02PD

Specification		
Sensing Method	Diffuse reflective	Through-beam
Light Source/Wavelength	Red LED (Visible)	
Sensing Distance	1M	20M
Standard Sensing Object	Opaque object	
Differential Travel	10% Max. of sensing distance	—
Response Time	1.0ms Max.	
Power Supply Voltage (Operating Voltage Range)	12-24VDC, Ripple (p-p) 10% Max. (10-30VDC)	
Current consumption	5mA Max. @NPN. 7mA Max. @PNP 100mA Max. @12VDC, 200mA Max. @24VDC	
Residual Voltage	2V Max.	
Ambient Illumination	Incandescent lamp 5000lx Max./Sunlight 10,000lx Max.	
Protection Circuit	Reverse Polarity/Overload/Short circuit protection/ Surge suppressor	
Ambient Temperature Range	Operating -25~+55°C / storage: -40~+70°C (with no icing or condensation)	
Ambient Humidity Range	Operating 35~85%/ storage: 35-95% (with no icing or condensation)	
Insulation Resistance	20MΩ Min. (at 500VDC) between current carrying parts and case	
Dielectric Strength	1000VAC 50/60Hz for 1 minute between current carrying parts and case	
Vibration Resistance	10-55Hz 1.5mm double amplitude for 2 hours each in X, Y, Z directions	
Shock Resistance	500 m/s ² 10 times each in X, Y and Z directions	
Degree of Protection	IEC standards: IP50	
Materials of Case/Sensing Surface	Case: PBT/ Sensing;Surface: Acrylate resin	
Connection Method	Pre-wired 2M	

Dimension Diagram Unit: mm

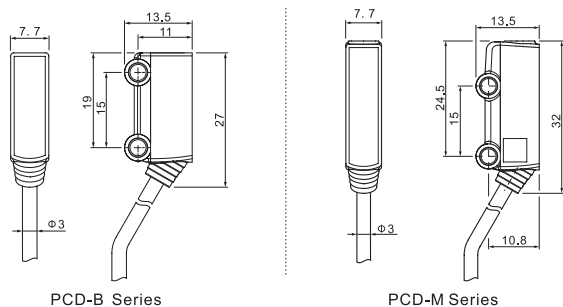

Wiring Diagram

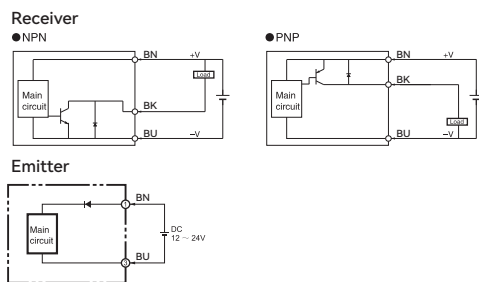

PY21	-	300	N
Series PY21 Series PY22 Series PY27 Series		Sensing Distance 300:300mm	Output Mode N:NPN LO+DO P:PNP LO+DO



- Features**
- Precise detection for variety of objects
 - Ultra small spot diameter
 - Reverse Polarity/Overload/Short circuit protection
 - Ambient temperature: -25~+55°C
 - IP65(PY21-300NC)

Mode			
NPN LO+DO	PY21- 300N	PY22- 300N	PY27- 300N
PNP LO+DO	PY21- 300P	PY22- 300P	PY27- 300P

Specification			
Sensing Method	Red diffuse reflection	Infrared diffuse reflection	Diffuse reflective
Sensing Distance	30~300mm		
Light Source	650nmRed light	780nm infrared light	660nm red laser
Sensing Object	Opaque object		
Response Time	1.0ms Max.		
Differential Travel	10% Max. of sensing distance		
Power Supply Voltage (Operating Voltage Range)	12-24VDC, Ripple (p-p) 10% Max.		
Current consumption	20mA @24VDC		
Load Current	100mA Max.		
Residual Voltage	2V Max. @100mA load, 2M cable		
Indicators	Red		
Operation Mode	N-(NPN LO+DO)/NL-(NPN LO)		
Protection Circuit	Reverse Polarity/Overload/Short circuit protection		
Ambient Temperature Range	Operating -25~+70°C / storage: -40~+70°C (with no icing or condensation)		
Ambient Humidity Range	Operating/ storage:35~85% (with no icing or condensation)		
Insulation Resistance	20MΩ Min. (at 500VDC) between current carrying parts and case		
Dielectric Strength	1000VAC 50/60Hz for 1 minute between current carrying parts and case		
Vibration/ Shock Resistance	10-55Hz 1.5mm double amplitude for 2 hours each in X, Y, Z directions		
Degree of Protection	IEC standards: IP50		
Connection Method	Pre-wired 2M		
Weight (Packed state)	~30g		
Materials of Case/Sensing Surface	Case: PBT/ Sensing;Surface: Acrylate resin		

Dimension Diagram Unit: mm

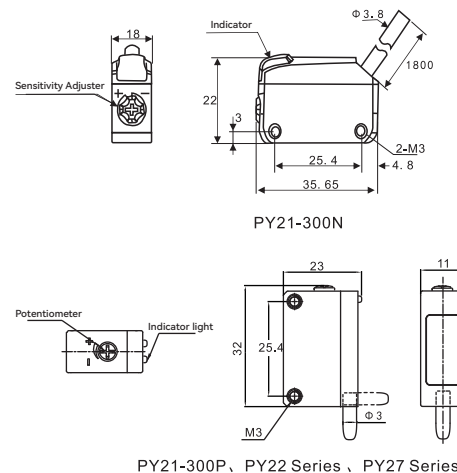

Wiring Diagram

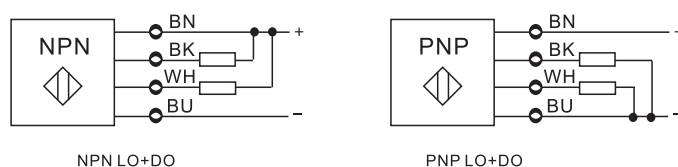



- Features
 - Precision flowing liquid level detection (PE-T series)
 - Viscous liquid level detection (PE-C series)
 - Detection for non-transparent pipe (PE-C series)
 - Level detection for $\Phi 6$ -13mm/ $\Phi 12$ -26mm pipe available

PE	-	T	13	NL
Series PE Series	Attribute	Sensing Distance T: Photoelectric type C: Capacitive	13: 13mm	Output Mode N: NPN P: PNP

Model	NPN LO+DO	PE-T13N	PE-C13NA	PE-C26NA
-------	-----------	---------	----------	----------

Specification	
Detection mode	Photoelectric type / Capacitance
Applicable catheter	Transparent conduit (FEP) of 6 to 13mm OD (thickness 1mm) or of equivalent transparency / Outside diameter of 3~13mm non-metallic disconnecting conduit / Outside diameter of 12~26mm non-metallic disconnecting conduit
Standard test object	Fluid in the catheter (if the fluid is of high viscosity or mixed with suspended matter, may not be detected) / The fluid in the catheter
Light source (luminous wavelength)	GaAs Infrared Light-emitting Diode (940nm) / —
Action indicator light	GaP lights up when entering light (red LED: maximum luminous wavelength 700nm) / Yellow LED
Supply voltage	12-24VDC, ripple (p-p) less than 10% (DC10-30V)
Current consumption	The average value is below 30mA and the maximum value is below 80mA Working : -25 ~ +70°C, storage : -40 ~ +85°C (no icing)
Control output	Load current below 100mA, NPN collector open output, residual voltage below 1V Working and storage : 35 ~ 95%(no condensation)
Use ambient illumination	Incandescent lamp, sunlight: each below 3000lx / —
Action pattern	Type N: NPN LO/DO / NA type :NO NA type: NPN NO
Ambient Humidity Range	Working: -10 ~ +55°C, storage: -25 ~ +65°C (no icing) / Working: -25 ~ +70°C, storage: -40 ~ +85°C (no icing)
Ambient humidity range	Working time: 5 ~ 85%RH, storage: 5 ~ 95%RH (no condensation) / Working and storage: 35 ~ 95% (no condensation)
Insulation resistance	Above 50M Ω , (DC500V megohm meter) charging part between the whole and the shell
Vithstand voltage	AC1000V 50/60HZ 1min charging part integral and housing
Vibration (durability)	10 ~ 500Hz up and down amplitude 1.0mm X, Y, Z 3 frequency sweeps in each direction (11min/ sweep)
Impact (durability)	500m/s double amplitude, 3 times in each direction X, Y, and Z
Protection architecture	IEC standards: IP50 / IEC standards: IP67
connection type	Pre-wired 2M
Quality (after packaging)	About 55g / About 40g
Shell material	ABS+PC / Plastic casing
Accessory	— / Standard nut mounting kit; The installation support is optional

Dimension Diagram Unit: mm

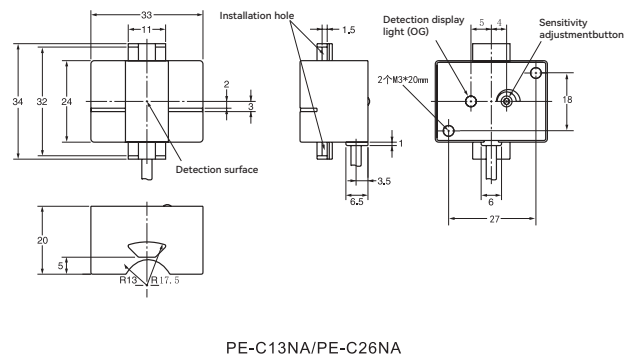
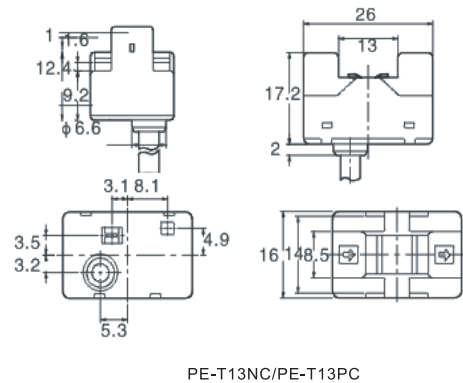

Wiring Diagram

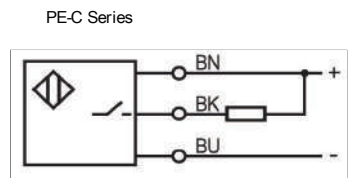
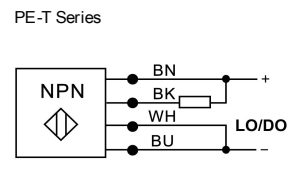



- Features
- One key one function design
- Stable detection
- Various fiber sensors available
- Reverse polarity & short circuit protection



- Features
- High performance & interference immunity
- Built-in self-tuning function
- 2-digits LED indicator. Intuitive & Convenient reading
- Detect precisely and stably
- Various fiber sensors available

PY2	-	300	N
Series PTX1 Series PTX2 Series		Sensing Distance G: Universal type E: Economical type	Output Mode N: NPN P: PNP

Specification

Type	PTX1 Series (simple fiber amplifier)		PTX2 Series (digital fiber amplifier)	
	PTX1-EN	PTX1-EP	PTX2-GN	PTX2-GP
Light Source	Red LED			
Power Supply Voltage	1.2~2.4VDC ±1.0% Ripple (p-p) 1.0% max.			
Power / Current Consumption	90.0 mW Max./40 mA Max.		96.0 mW Max./40 mA Max.	
Display Mode	Bar display		Digital display: Setting value (4 digits display-green) Current value (4 digits display-red)	
Output Mode	NPN	PNP	NPN	PNP
Operation Mode	LIGHT-ON/DARK-ON			
Response Time	Action or Reset: 200μs		P0: 25μs/P2: 400μs	
Sensitivity Adjustment	Rotary knob		Light intensity, Self-tuning/ Manual adjustment	
Residual Voltage	1V Max. @50mA Load, 24VDC Max.			
Timer	Time selector/40 ms (fixed)		OFF/ON delay timer, OFF/ON single delay timer: 0.1-9999ms	
Protect Circuit	Reverse polarity/short circuit protection.			
Ambient Illumination	Receiver: Incandescent light: 10,000 LX Max./Sunlight: 30,000 LX Max.			
Ambient Temperature Range ^①	Operating: -25~+55°C . Storage: -30~+70°C (with no icing or condensation)			
Ambient Humidity Range	Operating: 35~85% RH, Storage: 35~95% RH (with no condensation)			
Insulation Resistance	20MΩ Min. (at 500 VDC) between current carrying parts and case			
Dielectric strength	1000VAC 50/60Hz for 1 minute between current carrying parts and case			
Vibration Resistance	10~55Hz z1.5mm double amplitude for 2 hours each in X, Y, Z direction			
Shock Resistance	500m/s ² , 3 times each in X, Y, Z direction			
Degree of Protection	IEC Standard IP50 (with cover)			
Connection Method	Pre-wired cable (2m)			
Case Materials	Case: PBT, Cover: PC			

Dimension Diagram

Unit: mm

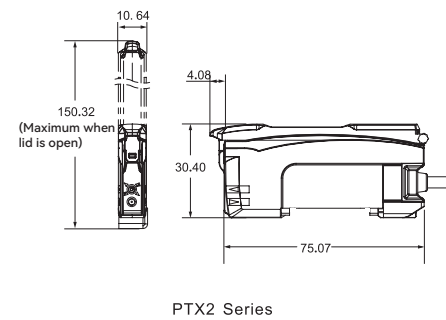
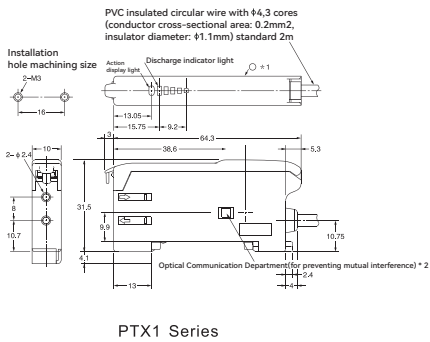

Wiring Diagram

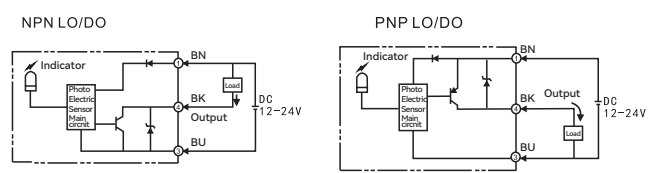

Fiber Unit (Purchase separately)

PT2	3	-	B	S	01	B
Series PT2 Series PT2A Series PT7 Series	Fiber Unit Size 3:M3		Sensing Method B: Diffuse Reflective T: Through beam	Fiber Type S: Coaxial single-core C: Coaxial multi-core	Fiber Length 0R5: 0.5M 01: 1M 02: 2M	Sensing Unit protruding length 00: Flat 10: 10mm 20: 20mm

PT2 Series standard fiber units

Sensing Method	Size	Model	Sensing distance(mm)	Min. sensing object	Outline
Diffuse reflective	M3	PT23-BS01	50	0.5	
		PT23-BS02	50	0.5	
		PT23-BS01/10	50	0.5	
		PT23-BS02/10	50	0.5	
		PT23-BS01/20	50	0.5	
		PT23-BS02/20	50	0.5	
	M4	PT24-BS01	50	0.5	
		PT24-BS02	50	0.5	
		PT24-BS01/10	60	0.5	
		PT24-BS02/10	60	0.5	
		PT24-BS01/20	60	0.5	
		PT24-BS02/20	60	0.5	
	M6	PT26-BS01	180	0.5	
		PT26-BS02	180	0.5	
		PT26-BS01/10	180	1.0	
		PT26-BS02/10	180	1.0	
		PT26-BS01/20	180	1.0	
		PT26-BS02/20	180	1.0	
Through-beam	M3	PT23-TS01	1000	1.0	
		PT23-TS02	1000	1.0	
	M4	PT24-TS01	1000	1.0	
		PT24-TS02	1000	1.0	
	M6	PT26-TS01	1000	1.0	
		PT26-TS02	1000	1.0	

PT2A Series L-shape Fiber Units

Sensing Method	Size	Model	Sensing distance(mm)	Min. sensing object	Outline
Diffuse reflective	M3	PT2A3-BS01	15	0.5	
		PT2A3-BS02	15	0.5	
		PT2A3-BC01	60	0.5	
		PT2A3-BC02	60	0.5	
	M4	PT2A4-BS01	15	0.5	
		PT2A4-BS02	15	0.5	
		PT2A4-BC01	60	0.5	
		PT2A4-BC02	60	0.5	
		PT2A4-BC02	60	0.5	
M6	PT2A6-BS01	60	0.5		
	PT2A6-BS02	60	0.5		
	PT2A6-BC01	140	1.0		
	PT2A6-BC02	140	1.0		
Through-beam	M3	PT2A3-TC01	600	0.5	
		PT2A3-TC02	600	0.5	
	M4	PT2A4-TC01	600	1.0	
		PT2A4-TC02	600	1.0	
	M6	PT2A6-TC01	600	2.0	
		PT2A6-TC02	600	2.0	

●PT7 Series 350°C High Temp Resistance

Sensing Method	Size	Model	Sensing distance(mm)	Min. sensing object	Outline
Diffuse reflective	M3	PT73-BS01	50	0.5	
		PT73-BS02	50	0.5	
	M4	PT74-BS01	50	0.5	
		PT74-BS02	50	0.5	
	M6	PT76-BS01	150	0.5	
		PT76-BS02	150	0.5	
Through-beam	M3	PT73-TS01	1000	1.0	
		PT73-TS02	1000	1.0	
	M4	PT74-TS01	1000	1.0	
		PT74-TS02	1000	1.0	

PT01 Series Lens

PT01	-	3	B	A1
Series PT01 Series		Fiber Unit Size 3:M3	Sensing Method B: Diffuse Reflective T: Through beam	Type

Focus type	Mode	Instruction	Dimension drawing
M3 Lens	PT01-3BA1	<p>Sensing distance=10mm Focus=Φ0.5 For M3 Fiber Working temperature:-50°C ~ +70°C</p>	<p>M3P0.5-5L</p>
M4 Lens	PT01-4BA1	<p>Sensing distance=20mm Focus=Φ1.5 For M4 Fiber Working temperature:-50°C ~ +70°C</p>	<p>M4P0.7-5L</p>
M4 Lens	PT01-6BA1	<p>Sensing distance=60mm Focus=Φ3.0 For M6 Fiber Working temperature:-50°C ~ +70°C</p>	



PM11	-	20	N	04	/	E
Series PM11 Series		FBeam Gap 10:10mm 20:20mm 40:40mm 60:60mm	Output Mode N:NPN DO P:PNP DO R:Relay	Number of Beams 4:4 Beams 6:6 Beams 10:10 Beams		Installation Mode E:Vertical Installation(Default) L:Horizontal Installation T:Accessory Pipe Installation

PM11	-	20	N	04	/	05	L	X	Non
Series PM12 Series		FBeam Gap 10:10mm 20:20mm 40:40mm 60:60mm	Output Mode N:NPN DO P:PNP DO R:Relay	Number of Beams 4:4 Beams 6:6 Beams 10:10 Beams		Mounting Interval 05:0.2-5M 10:5-10M 30:10-30M	Installation Mode L:Horizontal Installation(Default) E:Vertical Installation T:Accessory Pipe Installation	Synchronization Mode Non:Wired Sync. G:Optical Sync.	Safety-related functions Non:Nothing Floating Blanking Fixed Blanking Cross Through-beam

PM61	-	20	N	04
Series PM61 Series PM62 Series		FBeam Gap 10:10mm 20:20mm 40:40mm 60:60mm	Output Mode N:NPN DO P:PNP DO R:Relay	Number of Beams 4:4 Beams 6:6 Beams 10:10 Beams

PM81	-	20	N	04	/	05	L
Series PM81 Series PM84 Series		FBeam Gap 10:10mm 20:20mm 40:40mm 60:60mm	Output Mode N:NPN DO P:PNP DO R:Relay	Number of Beams 4:4 Beams 6:6 Beams 10:10 Beams		Mounting Interval 03:0.2-3M 06:3-6M	Installation Mode L:Horizontal Installation(Default) E:Vertical Installation

● Features

- Self-destect function,keep signal stable
- Good performance in interference resistance
- Metal housing
- Vibration ristance safe and reliable

Type

Series	Function	Beam Gap	Number of Beams	Sensing Distance	L×W (mm)	Appearance dimension
PM11 Series	Standard	10mm	4~72	3M	30*30	<p>A1: Upper end cover A2: Lower end cover+aviation terminal B1: Upper blind spot B2: Lower Blind Spot D: Optical axis spacing H: Height of grating protection L: Total height of grating</p> <p>A1=12mm A2=45mm B1=1/2 optical axis distance B2=1/2 optical axis spacing+27mm H=(Number of optical axes - 1) * Optical axis spacing L=number of optical axes * spacing between optical axes+84mm (including 33mm aviation terminals)</p>
		20mm	4~72			
		40mm	4~50			
		60mm	4~30			
PM12 Series	Long distance	10mm	4~72	5M/10M/ 30M	35*35	<p>A1: Upper end cover A2: Lower end cover+aviation terminal B1: Upper blind spot B2: Lower Blind Spot D: Optical axis spacing H: Height of grating protection L: Total height of grating</p> <p>A1=12mm A2=45mm B1=1/2 optical axis distance B2=1/2 optical axis spacing+27mm H=(Number of optical axes - 1) * Optical axis spacing L=number of optical axes * spacing between optical axes+84mm (including 33mm aviation terminals)</p>
		20mm	4~72			
		40mm	4~50			
		60mm	4~30			
PM61 Series	Ultra-slim (from side view)	5mm	8~72	2M	28*13	<p>B1: Upper blind spot B2: Lower Blind Spot D: Optical axis spacing H: Height of grating protection L: Total height of grating</p> <p>B1=1/2 optical axis distance+13mm (When selecting the upper and lower side mounting brackets, B1=1/2 optical axis spacing+3mm) B2=1/2 optical axis spacing+13mm (When selecting the upper and lower side mounting brackets, B2=1/2 optical axis spacing+3mm) L=number of optical axes * spacing between optical axes+26mm (When selecting the upper and lower side mounting brackets, L=number of optical axes * spacing between optical axes+6mm)</p>
		10mm	4~72			
		20mm	4~72			
		40mm	4~50			
PM62 Series	Ultra-slim (from front view)	10mm	4~72	2M	16*29	<p>B1: Upper blind spot B2: Lower Blind Spot D: Optical axis spacing H: Height of grating protection L: Total height of grating</p> <p>B1=1/2 optical axis distance+13mm B2=1/2 optical axis spacing+13mm L=number of optical axes * spacing between optical axes+26mm</p>
		20mm	4~72			
		30mm	4~72			
		40mm	4~50			
PM81 Series	Non-blind area	10mm	16~98	3M/6M	30*30	<p>B1: Upper blind spot B2: Lower Blind Spot D: Optical axis spacing H: Height of grating protection L: Total height of grating</p>
		20mm	16~98			
PM84 Series	4-class Non-blind area	10mm	16~98	3M/6M	30*30	<p>B1=1/2 optical axis distance+3mm B2=1/2 optical axis spacing+3mm L=number of optical axes * spacing between optical axes+6mm</p>
		20mm	16~98			

Beam Gap 10mm

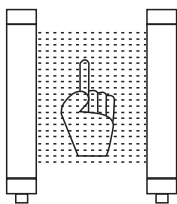

Beam Gap 20mm

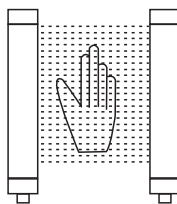

Beam Gap 40mm

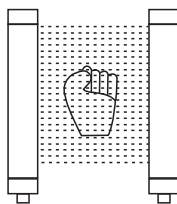

Beam Gap 80mm

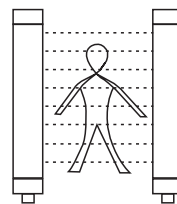

Specification	
Project	Performance parameter
Power supply voltage	24 VDC±20% (Ripple p-p 10 % Max.)
Response time	ON to OFF: 15ms Max. OFF to ON: 60ms Max.
Startup waiting time	2S Max.
Light source	Infrared LE D
Safety-related function	External device monitoring /Start interlock, Restart interlock
Connection method	Connector (M12, 8-pin)
Protect Circuit	Output broken protection / reverse polarity protection
Ambient Temperature Range	Operating: -10~55°C(with no icing), Storage: -25~70°C
Ambient Humidity Range	Operating: 35%~85% (with no icing), Storage: 35%~95%
Ambient Illumination	Receiver side: Incandescent light: 3,000LX Max. , Sunlight: 10,000LX Max.
Insulation Resistance	20MΩ Min. (at500 VDC)Between current carrying parts and case
Dielectric Voltage	1,000 VAC 50/6 0Hz 1min.
Protection class	IP65
Vibration resistance	Destruction:10 ~55Hz, 0.7mm double amplitude, 20 sweeps in each X、Y、Z direction
Shock resistance	Destruction:100m/s ² , 1000 shocks in each X、Y、Z direction

Wiring Diagram

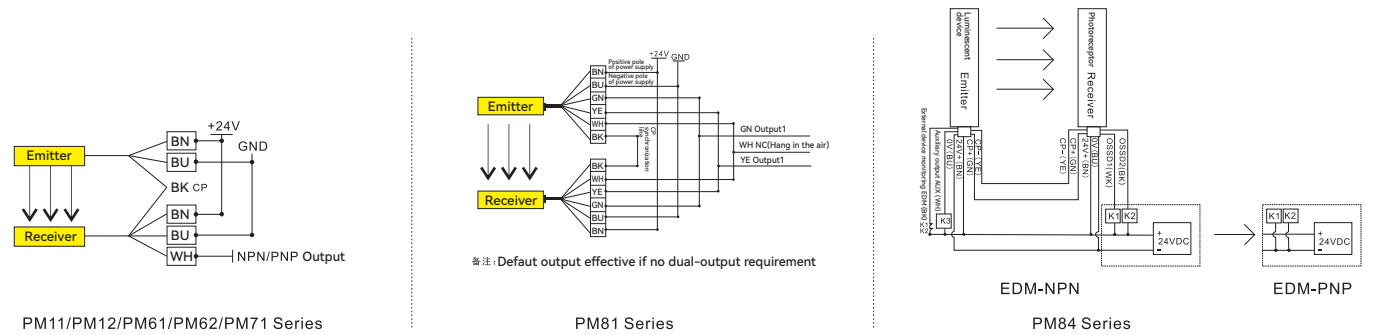

Ordering data

PM11 Series Standard Safety Light Curtain

Beam Gap	10mm			20mm			40mm			60mm		
	Number of Beams	Model ①	Sensing height(mm)	Model ①	Sensing height(mm)	Model height(mm)	Model ①	Sensing height(mm)	Model height(mm)	Model ①	Sensing height(mm)	Model height(mm)
4	PM11-10N04/(E,L,T)	30	124	PM11-20N04/(E,L,T)	60	164	PM11-40N04/(E,L,T)	120	244	PM11-60N04/(E,L,T)	180	324
6	PM11-10N06/(E,L,T)	50	144	PM11-20N06/(E,L,T)	100	204	PM11-40N06/(E,L,T)	200	324	PM11-60N06/(E,L,T)	300	444
8	PM11-10N08/(E,L,T)	70	164	PM11-20N08/(E,L,T)	140	244	PM11-40N08/(E,L,T)	280	404	PM11-60N08/(E,L,T)	420	564
10	PM11-10N10/(E,L,T)	90	184	PM11-20N10/(E,L,T)	180	284	PM11-40N10/(E,L,T)	360	484	PM11-60N10/(E,L,T)	540	684
12	PM11-10N12/(E,L,T)	110	204	PM11-20N12/(E,L,T)	220	324	PM11-40N12/(E,L,T)	440	564	PM11-60N12/(E,L,T)	660	804
14	PM11-10N14/(E,L,T)	130	224	PM11-20N14/(E,L,T)	260	364	PM11-40N14/(E,L,T)	520	644	PM11-60N14/(E,L,T)	780	924
16	PM11-10N16/(E,L,T)	150	244	PM11-20N16/(E,L,T)	300	404	PM11-40N16/(E,L,T)	600	724	PM11-60N16/(E,L,T)	900	1044
18	PM11-10N18/(E,L,T)	170	264	PM11-20N18/(E,L,T)	340	444	PM11-40N18/(E,L,T)	680	804	PM11-60N18/(E,L,T)	1020	1164
20	PM11-10N20/(E,L,T)	190	284	PM11-20N20/(E,L,T)	380	484	PM11-40N20/(E,L,T)	760	884	PM11-60N20/(E,L,T)	1140	1284
22	PM11-10N22/(E,L,T)	210	304	PM11-20N22/(E,L,T)	420	524	PM11-40N22/(E,L,T)	840	964	PM11-60N22/(E,L,T)	1260	1404
24	PM11-10N24/(E,L,T)	230	324	PM11-20N24/(E,L,T)	460	564	PM11-40N24/(E,L,T)	920	1044	PM11-60N24/(E,L,T)	1380	1524
26	PM11-10N26/(E,L,T)	250	344	PM11-20N26/(E,L,T)	500	604	PM11-40N26/(E,L,T)	1000	1124	PM11-60N26/(E,L,T)	1500	1644
28	PM11-10N28/(E,L,T)	270	364	PM11-20N28/(E,L,T)	540	644	PM11-40N28/(E,L,T)	1080	1204	PM11-60N28/(E,L,T)	1620	1764
30	PM11-10N30/(E,L,T)	290	384	PM11-20N30/(E,L,T)	580	684	PM11-40N30/(E,L,T)	1160	1284	PM11-60N30/(E,L,T)	1740	1884
32	PM11-10N32/(E,L,T)	310	404	PM11-20N32/(E,L,T)	620	724	PM11-40N32/(E,L,T)	1240	1364			
34	PM11-10N34/(E,L,T)	330	424	PM11-20N34/(E,L,T)	660	764	PM11-40N34/(E,L,T)	1320	1444			
36	PM11-10N36/(E,L,T)	350	444	PM11-20N36/(E,L,T)	700	804	PM11-40N36/(E,L,T)	1400	1524			
38	PM11-10N38/(E,L,T)	370	464	PM11-20N38/(E,L,T)	740	844	PM11-40N38/(E,L,T)	1480	1604			
40	PM11-10N40/(E,L,T)	390	484	PM11-20N40/(E,L,T)	780	884	PM11-40N40/(E,L,T)	1560	1684			
42	PM11-10N42/(E,L,T)	410	504	PM11-20N42/(E,L,T)	820	924	PM11-40N42/(E,L,T)	1640	1764			
44	PM11-10N44/(E,L,T)	430	524	PM11-20N44/(E,L,T)	860	964	PM11-40N44/(E,L,T)	1720	1844			
46	PM11-10N46/(E,L,T)	450	544	PM11-20N46/(E,L,T)	900	1004	PM11-40N46/(E,L,T)	1800	1924			
48	PM11-10N48/(E,L,T)	470	564	PM11-20N48/(E,L,T)	940	1044	PM11-40N48/(E,L,T)	1880	2004			
50	PM11-10N50/(E,L,T)	490	584	PM11-20N50/(E,L,T)	980	1084	PM11-40N50/(E,L,T)	1960	2084			
52	PM11-10N52/(E,L,T)	510	604	PM11-20N52/(E,L,T)	1020	1124						
54	PM11-10N54/(E,L,T)	530	624	PM11-20N54/(E,L,T)	1060	1164						
56	PM11-10N56/(E,L,T)	550	644	PM11-20N56/(E,L,T)	1100	1204						
58	PM11-10N58/(E,L,T)	570	664	PM11-20N58/(E,L,T)	1140	1244						
60	PM11-10N60/(E,L,T)	590	684	PM11-20N60/(E,L,T)	1180	1284						
62	PM11-10N62/(E,L,T)	610	704	PM11-20N62/(E,L,T)	1220	1324						
64	PM11-10N64/(E,L,T)	630	724	PM11-20N64/(E,L,T)	1260	1364						
66	PM11-10N66/(E,L,T)	650	744	PM11-20N66/(E,L,T)	1300	1404						
68	PM11-10N68/(E,L,T)	670	764	PM11-20N68/(E,L,T)	1340	1444						
70	PM11-10N70/(E,L,T)	690	784	PM11-20N70/(E,L,T)	1380	1484						
72	PM11-10N72/(E,L,T)	710	804	PM11-20N72/(E,L,T)	1420	1524						

Note①: The/(E, L, T) models are different installation methods, please choose according to the on-site design (default is/E, that is, upper and lower installation).

PM12 Series High Performance Safety Light Curtain(5M)

Beam Gap	10mm			20mm			40mm			60mm		
	Number of Beams	Model ①	Sensing height(mm) Model height(mm)	Model ①	Sensing height(mm) Model height(mm)	Model ①	Sensing height(mm) Model height(mm)	Model ①	Sensing height(mm) Model height(mm)	Model ①	Sensing height(mm) Model height(mm)	Model ①
4	PM12-10N04/05(L,E,T)	30	124	PM12-20N04/05(L,E,T)	60	164	PM12-40N04/05(L,E,T)	120	244	PM12-60N04/05(L,E,T)	180	324
6	PM12-10N06/05(L,E,T)	50	144	PM12-20N06/05(L,E,T)	100	204	PM12-40N06/05(L,E,T)	200	324	PM12-60N06/05(L,E,T)	300	444
8	PM12-10N08/05(L,E,T)	70	164	PM12-20N08/05(L,E,T)	140	244	PM12-40N08/05(L,E,T)	280	404	PM12-60N08/05(L,E,T)	420	564
10	PM12-10N10/05(L,E,T)	90	184	PM12-20N10/05(L,E,T)	180	284	PM12-40N10/05(L,E,T)	360	484	PM12-60N10/05(L,E,T)	540	684
12	PM12-10N12/05(L,E,T)	110	204	PM12-20N12/05(L,E,T)	220	324	PM12-40N12/05(L,E,T)	440	564	PM12-60N12/05(L,E,T)	660	804
14	PM12-10N14/05(L,E,T)	130	224	PM12-20N14/05(L,E,T)	260	364	PM12-40N14/05(L,E,T)	520	644	PM12-60N14/05(L,E,T)	780	924
16	PM12-10N16/05(L,E,T)	150	244	PM12-20N16/05(L,E,T)	300	404	PM12-40N16/05(L,E,T)	600	724	PM12-60N16/05(L,E,T)	900	1044
18	PM12-10N18/05(L,E,T)	170	264	PM12-20N18/05(L,E,T)	340	444	PM12-40N18/05(L,E,T)	680	804	PM12-60N18/05(L,E,T)	1020	1164
20	PM12-10N20/05(L,E,T)	190	284	PM12-20N20/05(L,E,T)	380	484	PM12-40N20/05(L,E,T)	760	884	PM12-60N20/05(L,E,T)	1140	1284
22	PM12-10N22/05(L,E,T)	210	304	PM12-20N22/05(L,E,T)	420	524	PM12-40N22/05(L,E,T)	840	964	PM12-60N22/05(L,E,T)	1260	1404
24	PM12-10N24/05(L,E,T)	230	324	PM12-20N24/05(L,E,T)	460	564	PM12-40N24/05(L,E,T)	920	1044	PM12-60N24/05(L,E,T)	1380	1524
26	PM12-10N26/05(L,E,T)	250	344	PM12-20N26/05(L,E,T)	500	604	PM12-40N26/05(L,E,T)	1000	1124	PM12-60N26/05(L,E,T)	1500	1644
28	PM12-10N28/05(L,E,T)	270	364	PM12-20N28/05(L,E,T)	540	644	PM12-40N28/05(L,E,T)	1080	1204	PM12-60N28/05(L,E,T)	1620	1764
30	PM12-10N30/05(L,E,T)	290	384	PM12-20N30/05(L,E,T)	580	684	PM12-40N30/05(L,E,T)	1160	1284	PM12-60N30/05(L,E,T)	1740	1884
32	PM12-10N32/05(L,E,T)	310	404	PM12-20N32/05(L,E,T)	620	724	PM12-40N32/05(L,E,T)	1240	1364			
34	PM12-10N34/05(L,E,T)	330	424	PM12-20N34/05(L,E,T)	660	764	PM12-40N34/05(L,E,T)	1320	1444			
36	PM12-10N36/05(L,E,T)	350	444	PM12-20N36/05(L,E,T)	700	804	PM12-40N36/05(L,E,T)	1400	1524			
38	PM12-10N38/05(L,E,T)	370	464	PM12-20N38/05(L,E,T)	740	844	PM12-40N38/05(L,E,T)	1480	1604			
40	PM12-10N40/05(L,E,T)	390	484	PM12-20N40/05(L,E,T)	780	884	PM12-40N40/05(L,E,T)	1560	1684			
42	PM12-10N42/05(L,E,T)	410	504	PM12-20N42/05(L,E,T)	820	924	PM12-40N42/05(L,E,T)	1640	1764			
44	PM12-10N44/05(L,E,T)	430	524	PM12-20N44/05(L,E,T)	860	964	PM12-40N44/05(L,E,T)	1720	1844			
46	PM12-10N46/05(L,E,T)	450	544	PM12-20N46/05(L,E,T)	900	1004	PM12-40N46/05(L,E,T)	1800	1924			
48	PM12-10N48/05(L,E,T)	470	564	PM12-20N48/05(L,E,T)	940	1044	PM12-40N48/05(L,E,T)	1880	2004			
50	PM12-10N50/05(L,E,T)	490	584	PM12-20N50/05(L,E,T)	980	1084	PM12-40N50/05(L,E,T)	1960	2084			
52	PM12-10N52/05(L,E,T)	510	604	PM12-20N52/05(L,E,T)	1020	1124						
54	PM12-10N54/05(L,E,T)	530	624	PM12-20N54/05(L,E,T)	1060	1164						
56	PM12-10N56/05(L,E,T)	550	644	PM12-20N56/05(L,E,T)	1100	1204						
58	PM12-10N58/05(L,E,T)	570	664	PM12-20N58/05(L,E,T)	1140	1244						
60	PM12-10N60/05(L,E,T)	590	684	PM12-20N60/05(L,E,T)	1180	1284						
62	PM12-10N62/05(L,E,T)	610	704	PM12-20N62/05(L,E,T)	1220	1324						
64	PM12-10N64/05(L,E,T)	630	724	PM12-20N64/05(L,E,T)	1260	1364						
66	PM12-10N66/05(L,E,T)	650	744	PM12-20N66/05(L,E,T)	1300	1404						
68	PM12-10N68/05(L,E,T)	670	764	PM12-20N68/05(L,E,T)	1340	1444						
70	PM12-10N70/05(L,E,T)	690	784	PM12-20N70/05(L,E,T)	1380	1484						
72	PM12-10N72/05(L,E,T)	710	804	PM12-20N72/05(L,E,T)	1420	1524						

Note①: The models/(L, E, T) are different installation methods, please choose according to the on-site design (default is/L, i.e. side installation).

PM12 Series High Performance Safety Light Curtain(10M)

Beam Gap	10mm			20mm			40mm			60mm		
	Number of Beams	Model ①	Sensing height(mm) Model height(mm)	Model ①	Sensing height(mm) Model height(mm)	Model ①	Sensing height(mm) Model height(mm)	Model ①	Sensing height(mm) Model height(mm)	Model ①	Sensing height(mm) Model height(mm)	Model ①
4	PM12-10N04/10(L,E,T)	30	124	PM12-20N04/10(L,E,T)	60	164	PM12-40N04/10(L,E,T)	120	244	PM12-60N04/10(L,E,T)	180	324
6	PM12-10N06/10(L,E,T)	50	144	PM12-20N06/10(L,E,T)	100	204	PM12-40N06/10(L,E,T)	200	324	PM12-60N06/10(L,E,T)	300	444
8	PM12-10N08/10(L,E,T)	70	164	PM12-20N08/10(L,E,T)	140	244	PM12-40N08/10(L,E,T)	280	404	PM12-60N08/10(L,E,T)	420	564
10	PM12-10N10/10(L,E,T)	90	184	PM12-20N10/10(L,E,T)	180	284	PM12-40N10/10(L,E,T)	360	484	PM12-60N10/10(L,E,T)	540	684
12	PM12-10N12/10(L,E,T)	110	204	PM12-20N12/10(L,E,T)	220	324	PM12-40N12/10(L,E,T)	440	564	PM12-60N12/10(L,E,T)	660	804
14	PM12-10N14/10(L,E,T)	130	224	PM12-20N14/10(L,E,T)	260	364	PM12-40N14/10(L,E,T)	520	644	PM12-60N14/10(L,E,T)	780	924
16	PM12-10N16/10(L,E,T)	150	244	PM12-20N16/10(L,E,T)	300	404	PM12-40N16/10(L,E,T)	600	724	PM12-60N16/10(L,E,T)	900	1044
18	PM12-10N18/10(L,E,T)	170	264	PM12-20N18/10(L,E,T)	340	444	PM12-40N18/10(L,E,T)	680	804	PM12-60N18/10(L,E,T)	1020	1164
20	PM12-10N20/10(L,E,T)	190	284	PM12-20N20/10(L,E,T)	380	484	PM12-40N20/10(L,E,T)	760	884	PM12-60N20/10(L,E,T)	1140	1284
22	PM12-10N22/10(L,E,T)	210	304	PM12-20N22/10(L,E,T)	420	524	PM12-40N22/10(L,E,T)	840	964	PM12-60N22/10(L,E,T)	1260	1404
24	PM12-10N24/10(L,E,T)	230	324	PM12-20N24/10(L,E,T)	460	564	PM12-40N24/10(L,E,T)	920	1044	PM12-60N24/10(L,E,T)	1380	1524
26	PM12-10N26/10(L,E,T)	250	344	PM12-20N26/10(L,E,T)	500	604	PM12-40N26/10(L,E,T)	1000	1124	PM12-60N26/10(L,E,T)	1500	1644
28	PM12-10N28/10(L,E,T)	270	364	PM12-20N28/10(L,E,T)	540	644	PM12-40N28/10(L,E,T)	1080	1204	PM12-60N28/10(L,E,T)	1620	1764
30	PM12-10N30/10(L,E,T)	290	384	PM12-20N30/10(L,E,T)	580	684	PM12-40N30/10(L,E,T)	1160	1284	PM12-60N30/10(L,E,T)	1740	1884
32	PM12-10N32/10(L,E,T)	310	404	PM12-20N32/10(L,E,T)	620	724	PM12-40N32/10(L,E,T)	1240	1364			
34	PM12-10N34/10(L,E,T)	330	424	PM12-20N34/10(L,E,T)	660	764	PM12-40N34/10(L,E,T)	1320	1444			
36	PM12-10N36/10(L,E,T)	350	444	PM12-20N36/10(L,E,T)	700	804	PM12-40N36/10(L,E,T)	1400	1524			
38	PM12-10N38/10(L,E,T)	370	464	PM12-20N38/10(L,E,T)	740	844	PM12-40N38/10(L,E,T)	1480	1604			
40	PM12-10N40/10(L,E,T)	390	484	PM12-20N40/10(L,E,T)	780	884	PM12-40N40/10(L,E,T)	1560	1684			
42	PM12-10N42/10(L,E,T)	410	504	PM12-20N42/10(L,E,T)	820	924	PM12-40N42/10(L,E,T)	1640	1764			
44	PM12-10N44/10(L,E,T)	430	524	PM12-20N44/10(L,E,T)	860	964	PM12-40N44/10(L,E,T)	1720	1844			
46	PM12-10N46/10(L,E,T)	450	544	PM12-20N46/10(L,E,T)	900	1004	PM12-40N46/10(L,E,T)	1800	1924			
48	PM12-10N48/10(L,E,T)	470	564	PM12-20N48/10(L,E,T)	940	1044	PM12-40N48/10(L,E,T)	1880	2004			
50	PM12-10N50/10(L,E,T)	490	584	PM12-20N50/10(L,E,T)	980	1084	PM12-40N50/10(L,E,T)	1960	2084			
52	PM12-10N52/10(L,E,T)	510	604	PM12-20N52/10(L,E,T)	1020	1124						
54	PM12-10N54/10(L,E,T)	530	624	PM12-20N54/10(L,E,T)	1060	1164						
56	PM12-10N56/10(L,E,T)	550	644	PM12-20N56/10(L,E,T)	1100	1204						
58	PM12-10N58/10(L,E,T)	570	664	PM12-20N58/10(L,E,T)	1140	1244						
60	PM12-10N60/10(L,E,T)	590	684	PM12-20N60/10(L,E,T)	1180	1284						
62	PM12-10N62/10(L,E,T)	610	704	PM12-20N62/10(L,E,T)	1220	1324						
64	PM12-10N64/10(L,E,T)	630	724	PM12-20N64/10(L,E,T)	1260	1364						
66	PM12-10N66/10(L,E,T)	650	744	PM12-20N66/10(L,E,T)	1300	1404						
68	PM12-10N68/10(L,E,T)	670	764	PM12-20N68/10(L,E,T)	1340	1444						
70	PM12-10N70/10(L,E,T)	690	784	PM12-20N70/10(L,E,T)	1380	1484						
72	PM12-10N72/10(L,E,T)	710	804	PM12-20N72/10(L,E,T)	1420	1524						

Note①: The models/(L, E, T) are different installation methods, please choose according to the on-site design (default is/L, i.e. side installation).

PM12 Series High Performance Safety Light Curtain(30M)

Beam Gap	10mm			20mm			40mm			60mm		
	Number of Beams	Model ①	Sensing height(mm)	Model ①	Sensing height(mm)	Model height(mm)	Model ①	Sensing height(mm)	Model height(mm)	Model ①	Sensing height(mm)	Model height(mm)
4	PM12-10N04/30(L,E,T)	30	124	PM12-20N04/30(L,E,T)	60	164	PM12-40N04/30(L,E,T)	120	244	PM12-60N04/30(L,E,T)	180	324
6	PM12-10N06/30(L,E,T)	50	144	PM12-20N06/30(L,E,T)	100	204	PM12-40N06/30(L,E,T)	200	324	PM12-60N06/30(L,E,T)	300	444
8	PM12-10N08/30(L,E,T)	70	164	PM12-20N08/30(L,E,T)	140	244	PM12-40N08/30(L,E,T)	280	404	PM12-60N08/30(L,E,T)	420	564
10	PM12-10N10/30(L,E,T)	90	184	PM12-20N10/30(L,E,T)	180	284	PM12-40N10/30(L,E,T)	360	484	PM12-60N10/30(L,E,T)	540	684
12	PM12-10N12/30(L,E,T)	110	204	PM12-20N12/30(L,E,T)	220	324	PM12-40N12/30(L,E,T)	440	564	PM12-60N12/30(L,E,T)	660	804
14	PM12-10N14/30(L,E,T)	130	224	PM12-20N14/30(L,E,T)	260	364	PM12-40N14/30(L,E,T)	520	644	PM12-60N14/30(L,E,T)	780	924
16	PM12-10N16/30(L,E,T)	150	244	PM12-20N16/30(L,E,T)	300	404	PM12-40N16/30(L,E,T)	600	724	PM12-60N16/30(L,E,T)	900	1044
18	PM12-10N18/30(L,E,T)	170	264	PM12-20N18/30(L,E,T)	340	444	PM12-40N18/30(L,E,T)	680	804	PM12-60N18/30(L,E,T)	1020	1164
20	PM12-10N20/30(L,E,T)	190	284	PM12-20N20/30(L,E,T)	380	484	PM12-40N20/30(L,E,T)	760	884	PM12-60N20/30(L,E,T)	1140	1284
22	PM12-10N22/30(L,E,T)	210	304	PM12-20N22/30(L,E,T)	420	524	PM12-40N22/30(L,E,T)	840	964	PM12-60N22/30(L,E,T)	1260	1404
24	PM12-10N24/30(L,E,T)	230	324	PM12-20N24/30(L,E,T)	460	564	PM12-40N24/30(L,E,T)	920	1044	PM12-60N24/30(L,E,T)	1380	1524
26	PM12-10N26/30(L,E,T)	250	344	PM12-20N26/30(L,E,T)	500	604	PM12-40N26/30(L,E,T)	1000	1124	PM12-60N26/30(L,E,T)	1500	1644
28	PM12-10N28/30(L,E,T)	270	364	PM12-20N28/30(L,E,T)	540	644	PM12-40N28/30(L,E,T)	1080	1204	PM12-60N28/30(L,E,T)	1620	1764
30	PM12-10N30/30(L,E,T)	290	384	PM12-20N30/30(L,E,T)	580	684	PM12-40N30/30(L,E,T)	1160	1284	PM12-60N30/30(L,E,T)	1740	1884
32	PM12-10N32/30(L,E,T)	310	404	PM12-20N32/30(L,E,T)	620	724	PM12-40N32/30(L,E,T)	1240	1364			
34	PM12-10N34/30(L,E,T)	330	424	PM12-20N34/30(L,E,T)	660	764	PM12-40N34/30(L,E,T)	1320	1444			
36	PM12-10N36/30(L,E,T)	350	444	PM12-20N36/30(L,E,T)	700	804	PM12-40N36/30(L,E,T)	1400	1524			
38	PM12-10N38/30(L,E,T)	370	464	PM12-20N38/30(L,E,T)	740	844	PM12-40N38/30(L,E,T)	1480	1604			
40	PM12-10N40/30(L,E,T)	390	484	PM12-20N40/30(L,E,T)	780	884	PM12-40N40/30(L,E,T)	1560	1684			
42	PM12-10N42/30(L,E,T)	410	504	PM12-20N42/30(L,E,T)	820	924	PM12-40N42/30(L,E,T)	1640	1764			
44	PM12-10N44/30(L,E,T)	430	524	PM12-20N44/30(L,E,T)	860	964	PM12-40N44/30(L,E,T)	1720	1844			
46	PM12-10N46/30(L,E,T)	450	544	PM12-20N46/30(L,E,T)	900	1004	PM12-40N46/30(L,E,T)	1800	1924			
48	PM12-10N48/30(L,E,T)	470	564	PM12-20N48/30(L,E,T)	940	1044	PM12-40N48/30(L,E,T)	1880	2004			
50	PM12-10N50/30(L,E,T)	490	584	PM12-20N50/30(L,E,T)	980	1084	PM12-40N50/30(L,E,T)	1960	2084			
52	PM12-10N52/30(L,E,T)	510	604	PM12-20N52/30(L,E,T)	1020	1124						
54	PM12-10N54/30(L,E,T)	530	624	PM12-20N54/30(L,E,T)	1060	1164						
56	PM12-10N56/30(L,E,T)	550	644	PM12-20N56/30(L,E,T)	1100	1204						
58	PM12-10N58/30(L,E,T)	570	664	PM12-20N58/30(L,E,T)	1140	1244						
60	PM12-10N60/30(L,E,T)	590	684	PM12-20N60/30(L,E,T)	1180	1284						
62	PM12-10N62/30(L,E,T)	610	704	PM12-20N62/30(L,E,T)	1220	1324						
64	PM12-10N64/30(L,E,T)	630	724	PM12-20N64/30(L,E,T)	1260	1364						
66	PM12-10N66/30(L,E,T)	650	744	PM12-20N66/30(L,E,T)	1300	1404						
68	PM12-10N68/30(L,E,T)	670	764	PM12-20N68/30(L,E,T)	1340	1444						
70	PM12-10N70/30(L,E,T)	690	784	PM12-20N70/30(L,E,T)	1380	1484						
72	PM12-10N72/30(L,E,T)	710	804	PM12-20N72/30(L,E,T)	1420	1524						

PM61 Series Ultra slim safety light curtain (from side view)

Beam Gap	5mm			10mm			20mm			40mm		
	Number of Beams	Model ①	Sensing height(mm)	Model ①	Sensing height(mm)	Model height(mm)	Model ①	Sensing height(mm)	Model height(mm)	Model ①	Sensing height(mm)	Model height(mm)
4	-	-	-	PM61-10N04	30	78	PM61-20N04	120	186	PM61-40N04	180	266
6	-	-	-	PM61-10N06	50	86	PM61-20N06	200	266	PM61-40N06	300	386
8	PM61-05N08	35	78	PM61-10N08	70	106	PM61-20N08	280	346	PM61-40N08	420	506
10	-	-	-	PM61-10N10	90	126	PM61-20N10	360	426	PM61-40N10	540	626
12	-	-	-	PM61-10N12	110	146	PM61-20N12	440	506	PM61-40N12	660	746
14	-	-	-	PM61-10N14	130	166	PM61-20N14	520	586	PM61-40N14	780	866
16	PM61-05N16	75	106	PM61-10N16	150	186	PM61-20N16	600	666	PM61-40N16	900	986
18	-	-	-	PM61-10N18	170	206	PM61-20N18	680	746	PM61-40N18	1020	1106
20	-	-	-	PM61-10N20	190	226	PM61-20N20	760	826	PM61-40N20	1140	1226
22	-	-	-	PM61-10N22	210	246	PM61-20N22	840	906	PM61-40N22	1260	1346
24	PM61-05N24	115	186	PM61-10N24	230	266	PM61-20N24	920	986	PM61-40N24	1380	1466
26	-	-	-	PM61-10N26	250	286	PM61-20N26	1000	1066	PM61-40N26	1500	1586
28	-	-	-	PM61-10N28	270	306	PM61-20N28	1080	1146	PM61-40N28	1620	1706
30	-	-	-	PM61-10N30	290	326	PM61-20N30	1160	1226	PM61-40N30	1740	1826
32	PM61-05N32	155	186	PM61-10N32	310	346	PM61-20N32	1240	1306			
34	-	-	-	PM61-10N34	330	366	PM61-20N34	1320	1386			
36	-	-	-	PM61-10N36	350	386	PM61-20N36	1400	1466			
38	-	-	-	PM61-10N38	370	406	PM61-20N38	1480	1546			
40	PM61-05N40	195	226	PM61-10N40	390	426	PM61-20N40	1560	1626			
42	-	-	-	PM61-10N42	410	446	PM61-20N42	1640	1706			
44	-	-	-	PM61-10N44	430	466	PM61-20N44	1720	1786			
46	-	-	-	PM61-10N46	450	486	PM61-20N46	1800	1866			
48	PM61-05N48	235	266	PM61-10N48	470	506	PM61-20N48	1880	1946			
50	-	-	-	PM61-10N50	490	526	PM61-20N50	1960	2026			
52	-	-	-	PM61-10N52	510	546						
54	-	-	-	PM61-10N54	530	566						
56	PM61-05N56	275	306	PM61-10N56	550	586						
58	-	-	-	PM61-10N58	570	606						
60	-	-	-	PM61-10N60	590	626						
62	-	-	-	PM61-10N62	610	646						
64	PM61-05N64	315	346	PM61-10N64	630	666						
66	-	-	-	PM61-10N66	650	686						
68	-	-	-	PM61-10N68	670	706						
70	-	-	-	PM61-10N70	690	726						
72	PM61-05N72	355	386	PM61-10N72	710	746						

PM62 Series Ultra slim safety light curtain (from front view)

Beam Gap	10mm			20mm			40mm		
	Model ①	Sensing height(mm)	Model height(mm)	Model ①	Sensing height(mm)	Model height(mm)	Model ①	Sensing height(mm)	Model height(mm)
4	PM62-10N04	30	58	PM62-20N04	60	86	PM62-40N04	120	166
6	PM62-10N06	50	66	PM62-20N06	100	126	PM62-40N06	200	246
8	PM62-10N08	70	86	PM62-20N08	140	166	PM62-40N08	280	326
10	PM62-10N10	90	106	PM62-20N10	180	206	PM62-40N10	360	406
12	PM62-10N12	110	126	PM62-20N12	220	246	PM62-40N12	440	486
14	PM62-10N14	130	146	PM62-20N14	260	286	PM62-40N14	520	566
16	PM62-10N16	150	166	PM62-20N16	300	326	PM62-40N16	600	646
18	PM62-10N18	170	186	PM62-20N18	340	366	PM62-40N18	680	726
20	PM62-10N20	190	206	PM62-20N20	380	406	PM62-40N20	760	806
22	PM62-10N22	210	226	PM62-20N22	420	446	PM62-40N22	840	886
24	PM62-10N24	230	246	PM62-20N24	460	486	PM62-40N24	920	966
26	PM62-10N26	250	266	PM62-20N26	500	526	PM62-40N26	1000	1046
28	PM62-10N28	270	286	PM62-20N28	540	566	PM62-40N28	1080	1126
30	PM62-10N30	290	306	PM62-20N30	580	606	PM62-40N30	1160	1206
32	PM62-10N32	310	326	PM62-20N32	620	646	PM62-40N32	1240	1286
34	PM62-10N34	330	346	PM62-20N34	660	686	PM62-40N34	1320	1366
36	PM62-10N36	350	366	PM62-20N36	700	726	PM62-40N36	1400	1446
38	PM62-10N38	370	386	PM62-20N38	740	766	PM62-40N38	1480	1526
40	PM62-10N40	390	406	PM62-20N40	780	806	PM62-40N40	1560	1606
42	PM62-10N42	410	426	PM62-20N42	820	846	PM62-40N42	1640	1686
44	PM62-10N44	430	446	PM62-20N44	860	886	PM62-40N44	1720	1766
46	PM62-10N46	450	466	PM62-20N46	900	926	PM62-40N46	1800	1846
48	PM62-10N48	470	486	PM62-20N48	940	966	PM62-40N48	1880	1926
50	PM62-10N50	490	506	PM62-20N50	980	1006	PM62-40N50	1960	2006
52	PM62-10N52	510	526	PM62-20N52	1020	1046			
54	PM62-10N54	530	546	PM62-20N54	1060	1086			
56	PM62-10N56	550	566	PM62-20N56	1100	1126			
58	PM62-10N58	570	586	PM62-20N58	1140	1166			
60	PM62-10N60	590	606	PM62-20N60	1180	1206			
62	PM62-10N62	610	626	PM62-20N62	1220	1246			
64	PM62-10N64	630	646	PM62-20N64	1260	1286			
66	PM62-10N66	650	666	PM62-20N66	1300	1326			
68	PM62-10N68	670	686	PM62-20N68	1340	1366			
70	PM62-10N70	690	706	PM62-20N70	1380	1406			
72	PM62-10N72	710	726	PM62-20N72	1420	1446			

PM81 Series Non-blind area safety light curtain (3M)

Beam Gap	20mm		
Number of Beams	Model ①	Sensing height(mm)	Model height(mm)
8	PM81-20N08/03(L,T)	140	166
10	PM81-20N10/03(L,T)	180	206
12	PM81-20N12/03(L,T)	220	246
14	PM81-20N14/03(L,T)	260	286
16	PM81-20N16/03(L,T)	300	326
18	PM81-20N18/03(L,T)	340	366
20	PM81-20N20/03(L,T)	380	406
22	PM81-20N22/03(L,T)	420	446
24	PM81-20N24/03(L,T)	460	486
26	PM81-20N26/03(L,T)	500	526
28	PM81-20N28/03(L,T)	540	566
30	PM81-20N30/03(L,T)	580	606
32	PM81-20N32/03(L,T)	620	646
34	PM81-20N34/03(L,T)	660	686
36	PM81-20N36/03(L,T)	700	726
38	PM81-20N38/03(L,T)	740	766
40	PM81-20N40/03(L,T)	780	806

Note ①: L, T represents different installation methods, please choose according to the on-site design.

PM84 Series 4 class Non-blind area safety light curtain (3M)

Beam Gap	20mm		
Number of Beams	Model ①	Sensing height(mm)	Model height(mm)
8	PM84-20N08/03(L,T)	140	166
10	PM84-20N10/03(L,T)	180	206
12	PM84-20N12/03(L,T)	220	246
14	PM84-20N14/03(L,T)	260	286
16	PM84-20N16/03(L,T)	300	326
18	PM84-20N18/03(L,T)	340	366
20	PM84-20N20/03(L,T)	380	406
22	PM84-20N22/03(L,T)	420	446
24	PM84-20N24/03(L,T)	460	486
26	PM84-20N26/03(L,T)	500	526
28	PM84-20N28/03(L,T)	540	566
30	PM84-20N30/03(L,T)	580	606
32	PM84-20N32/03(L,T)	620	646
34	PM84-20N34/03(L,T)	660	686
36	PM84-20N36/03(L,T)	700	726
38	PM84-20N38/03(L,T)	740	766
40	PM84-20N40/03(L,T)	780	806

Note ①: L, T represents different installation methods, please choose according to the on-site design.

PM81 Series Non-blind area safety light curtain (6M)

Beam Gap	20mm		
Number of Beams	Model ①	Sensing height(mm)	Model height(mm)
8	PM81-20N08/06(L,T)	140	166
10	PM81-20N10/06(L,T)	180	206
12	PM81-20N12/06(L,T)	220	246
14	PM81-20N14/06(L,T)	260	286
16	PM81-20N16/06(L,T)	300	326
18	PM81-20N18/06(L,T)	340	366
20	PM81-20N20/06(L,T)	380	406
22	PM81-20N22/06(L,T)	420	446
24	PM81-20N24/06(L,T)	460	486
26	PM81-20N26/06(L,T)	500	526
28	PM81-20N28/06(L,T)	540	566
30	PM81-20N30/06(L,T)	580	606
32	PM81-20N32/06(L,T)	620	646
34	PM81-20N34/06(L,T)	660	686
36	PM81-20N36/06(L,T)	700	726
38	PM81-20N38/06(L,T)	740	766
40	PM81-20N40/06(L,T)	780	806

Note ①: L, T represents different installation methods, please choose according to the on-site design.

PM84 Series 4 class Non-blind area safety light curtain (6M)

Beam Gap	20mm		
Number of Beams	Model ①	Sensing height(mm)	Model height(mm)
8	PM84-20N08/06(L,T)	140	166
10	PM84-20N10/06(L,T)	180	206
12	PM84-20N12/06(L,T)	220	246
14	PM84-20N14/06(L,T)	260	286
16	PM84-20N16/06(L,T)	300	326
18	PM84-20N18/06(L,T)	340	366
20	PM84-20N20/06(L,T)	380	406
22	PM84-20N22/06(L,T)	420	446
24	PM84-20N24/06(L,T)	460	486
26	PM84-20N26/06(L,T)	500	526
28	PM84-20N28/06(L,T)	540	566
30	PM84-20N30/06(L,T)	580	606
32	PM84-20N32/06(L,T)	620	646
34	PM84-20N34/06(L,T)	660	686
36	PM84-20N36/06(L,T)	700	726
38	PM84-20N38/06(L,T)	740	766
40	PM84-20N40/06(L,T)	780	806

Note ①: L, T represents different installation methods, please choose according to the on-site design.

Mibbo

Add: Taiwan Technology Business Incubator,Torch(Xiangan)Industrial Park,Xiamen,Fujian,China
Zip Code: 361101 Tel: +86-592-5651090 Fax: +86-592-5651085 <http://www.mibbo.com>



※Due to changes in standards and materials, the characteristics described in this article and the images in this material are subject to change without prior notice,please confirm to our business department.

Subscription No: PM-QP01

More products information,
please download on Mibbo.com.cn
Thank you for your contribution to energy
conservation and environment protection.

